

**10/16/06 DRAFT**

**NEW YORK STATE RELIABILITY COUNCIL, L.L.C.  
("NYSRC")  
POLICY NO. 5-1**

**PROCEDURE FOR ESTABLISHING  
NEW YORK CONTROL AREA  
INSTALLED CAPACITY REQUIREMENTS**

**Approved by NYSRC Executive Committee –  
Date Issued:**

## TABLE OF CONTENTS

SECTION 1: INTRODUCTION .....	1
SECTION 2: OVERVIEW OF THE RELIABILITY CALCULATION PROCESS.....	1
2.1 CALCULATION PROCESS .....	1
2.2 TIMELINE .....	2
2.3 IRM STUDY REPORTING REQUIREMENTS .....	4
SECTION 3: RELIABILITY CALCULATION .....	4
3.1 NYSRC RESOURCE ADEQUACY CRITERION.....	4
3.2 COMPUTER PROGRAM USED FOR RELIABILITY CALCULATION .....	5
3.3 NYCA ZONES AND OUTSIDE WORLD REPRESENTATION.....	6
3.4 CONDUCT OF THE MARS ANALYSIS.....	6
3.5 INPUT DATA AND MODELS.....	9
3.5.1 NYCA Load Model.....	9
3.5.2 NYCA Capacity Model.....	9
3.5.3 Emergency Operating Procedures (EOPs).....	11
3.5.4 Transmission System Model.....	11
3.5.5 Locational Capacity Requirements.....	11
3.5.6 Outside World Area Load and Capacity Models.....	12
3.5.7 Data Base Accuracy .....	13
3.6 Data Base Confidentiality .....	13
SECTION 4: RESPONSIBILITIES .....	13
4.1 INSTALLED CAPACITY SUBCOMMITTEE .....	13
4.2 NYISO .....	13
4.3 MARKET PARTICIPANTS.....	14
4.4 NYSRC EXECUTIVE COMMITTEE .....	14

APPENDIX A Unified Methodology Description

APPENDIX B Selection of TAN 45 Points on IRM/LCR Curves Established by the Unified Methodology

## **Section 1: Introduction**

The reliable supply of electric services within the New York Control Area (NYCA) depends on adequate and dependable generation and transmission facilities. This policy focuses on the supply of electricity; specifically, the process that will be followed by the New York State Reliability Council (NYSRC) for determining and setting the amount of resource capacity required to ensure an acceptable level of service reliability in the NYCA.

The general requirements and obligations concerning NYCA resource adequacy and Installed Capacity Requirements (ICR) are defined in the New York State Reliability Council (NYSRC) Agreement and the New York Independent System Operator (NYISO)/NYSRC Agreement. Under these Agreements the NYSRC is responsible for calculating and establishing the amount of resource ICR to meet NYSRC Reliability Rules. In compliance with this obligation, the NYSRC Executive Committee approves an NYCA required Installed Reserve Margin (IRM) requirement for the following May through April capability year. The ICR relates to the IRM through the following equation:

$$\text{ICR} = (1 + \text{IRM}\%/100) \times \text{Forecasted NYCA Peak Load}$$

The final NYCA IRM requirement, as approved by the NYSRC Executive Committee, is the basis for various installed capacity analyses conducted by the NYISO. These NYISO analyses include the determination of the capacity obligation of each Load Serving Entity (LSE) on a Transmission District basis, as well as Locational Installed Capacity Requirements, for the following capability year. These NYISO analyses are conducted in accordance with NYSRC Reliability Rules and Procedures.

## **Section 2: Overview of the Reliability Calculation Process**

This section provides an overview of the NYSRC reliability calculation process, including the major modeling parameters for establishing statewide IRM requirements, a timeline for this process, and reporting requirements for the technical IRM study (IRM Study).

### **2.1 Calculation Process**

The reliability calculation process for determining the NYCA IRM requirement utilizes a probabilistic approach. This technique calculates the probabilities of outages of generating units, in conjunction with load and transmission models, to determine the number of days per year of expected capacity shortages. The General Electric Multi-Area Reliability Simulation (MARS) is the primary computer program used for this probabilistic analysis. The result of the calculation is termed Loss of Load Expectation (LOLE), which provides a consistent measure of system reliability. The relationship between MARS and the various models used in the NYCA IRM calculation process is depicted in Figure 2-1. The Installed Capacity Subcommittee (ICS) of the NYSRC has the responsibility of monitoring these studies and preparing reports for establishing NYCA ICR.

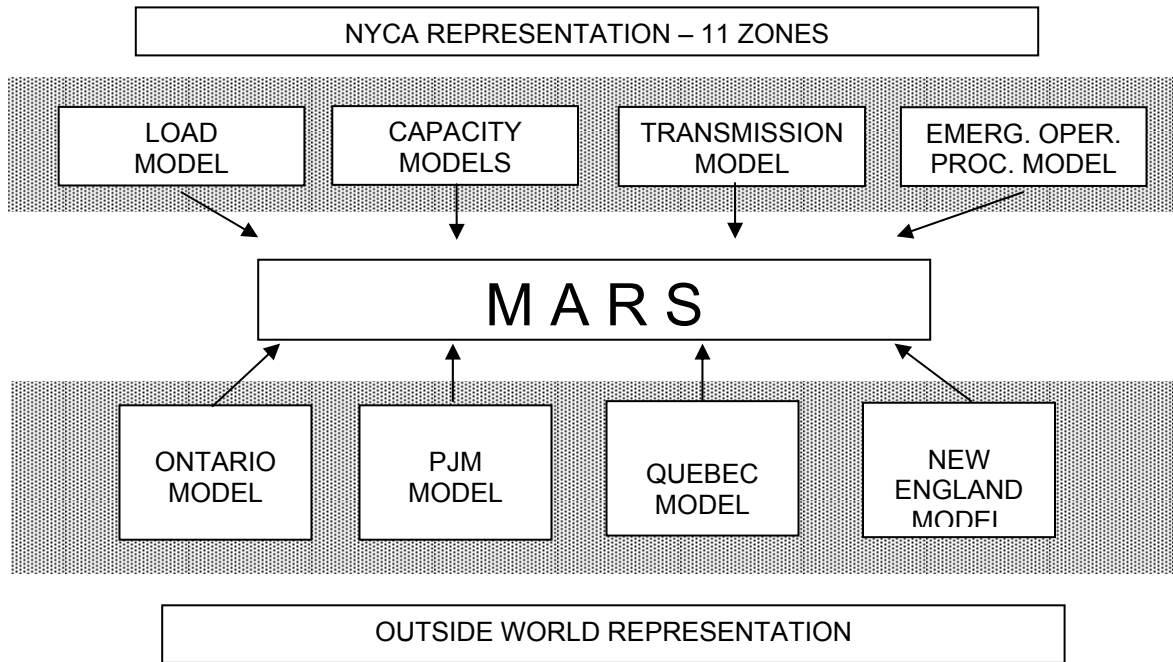

**Figure 2-1: Relationship between MARS and the Models Used In the IRM Requirement Calculation Process**

## 2.2 Timeline

A timeline for establishing NYCA IRM requirements is shown in Figure 2-2. This timeline is based on providing the NYISO with next year's NYCA IRM requirement by January, when the NYISO, under its installed capacity and procurement process, is required to begin its studies for determining the following summer's LSE capacity obligations.

DAY	YEAR	EVENT/DEADLINE	
Jan. 1	Y-1		
Mar. 1		ICS, with support from the NYISO and Market Participants, begin development of IRM Study database.	
June 1		NYISO completes transmission model. GE provides latest MARS executable for ICS benchmarking	
July 1		NYISO completes benchmarking tests for new MARS version.	
Aug. 1		ICS completes database assumption matrix and submits to the Executive Committee for review and approval.	
Sept. 15		ICS completes preliminary base case.	
Oct. 1		NYISO completes final NYCA load forecast and ICS identifies sensitivity tests to be examined.	
Oct, 15		ICS completes final base case.	
Nov. 1		ICS completes sensitivity testing and IRM Study draft, and submits to the Executive Committee for review and comment.	
Dec. 15		Executive Committee approves final IRM Study and establishes the NYCA IRM requirement for Year Y.	
Jan. 1		Y	

Y represents year for which NYCA ICR is established

**Figure 2-2: NYCA Installed Capacity Requirement Establishment Timeline**

The basic steps in the process of establishing NYCA IRM requirements are:

- *March 1* – The ICS begins the process of developing base case input data and modeling assumptions and approves the MARS computer program version to be used.
- *June 1* – The NYISO completes the transmission model and submits it to ICS for review.
- *July 1* - If a new MARS version is to be used in the IRM study, the NYISO completes benchmarking tests and submits results to ICS for review.
- *August 1* – ICS finalizes initial base case input data and modeling assumptions and transmits this information to the NYSRC Executive Committee for review and approval.
- *September 15* – ICS completes the preliminary base case following modeling review and benchmarking.
- *October 1* – The NYISO completes its final forecast and submits to ICS. This forecast replaces the preliminary forecast in the initial base case assumptions. ICS identifies sensitivity tests to be examined.
- *October 15* – ICS completes the final base case. These results are submitted to the Executive Committee review.
- *November 1* – ICS completes sensitivity testing and draft NYCA ICR technical report and submits report to the NYSRC Executive Committee for review and comment at its November meeting.
- *December 15* – NYSRC Executive Committee approves the IRM Study and establishes the NYCA IRM requirement for the following capability year based on the analysis in the report, considering base case as well as sensitivity case results, and other factors. The NYSRC Executive Committee also prepares an IRM resolution and issues a letter to the NYISO CEO, which specifies the NYCA IRM requirement for the next capability period.

Adherence to this schedule is required to support NYSRC annual filing with FERC to advise FERC of the annual state-wide IRM requirement for the New York control area for the following capability year and to seek FERC approval of any revision to the IRM requirement.

## **2.3 IRM Study Reporting Requirements**

In accordance with the NYSRC Reliability Rules, the NYSRC prepares the IRM Study, a technical report providing the assumptions, procedures, and results of analyses for determining NYCA IRM requirements. Drafts of this report are posted on the NYSRC web site and comments from all market participants are solicited during the NYCA IRM determination process in accordance with NYSRC Openness Policy 2.

## **Section 3: Reliability Calculation**

This section contains the criterion used for establishing the required NYCA IRM level, a description of the reliability calculation, including the primary computer program used, and a description of the input data and models used in the reliability calculation.

### **3.1 NYSRC Resource Adequacy Criterion**

The acceptable LOLE reliability level in the NYCA is stated in the NYSRC Reliability Rules. NYSRC Reliability Rule A-R1, *Statewide Installed Reserve Margin Requirements*, states:

*Adequate resource capacity shall exist in the NYCA such that, after due allowance for scheduled outages and deratings, forced outages and deratings, assistance from neighboring systems, NYS Transmission System transfer capability, uncertainty of load forecasts, and capacity and/or load relief from available operating procedures, the probability of disconnecting firm load due to a resource deficiency will be, on the average, no more than once in ten (10) years.*

This Rule is consistent with the NPCC Resource Adequacy Standard and may be modified in the future, as appropriate, in accordance with the NYSRC open process procedure for modifying NYSRC Reliability Rules (NYSRC Policy 1).

### **3.2 Computer Program Used for Reliability Calculation**

The primary tool used in the probabilistic analysis for establishing NYCA IRM requirements is a General Electric computer program called the Multi-Area Reliability Simulation (MARS). This program includes a detailed load, generation, and transmission representation for 11 NYCA zones (A through K), as well as the four external Control Areas (Outside World Areas) interconnected to the NYCA (see Section 3.3 for a description of these zones and Outside World Areas).

A sequential Monte Carlo simulation forms the basis for MARS. The Monte Carlo method provides a fast, versatile, and easily expandable program that can be used to fully model many different types of generation and demand-side options.

The MARS program calculates the standard reliability indices of daily and hourly LOLE (days/year and hours/year) and Loss of Energy Expectation (LOEE in MWh/year). The use of sequential Monte Carlo simulation allows for the calculation of time-correlated measures such as frequency (outages/year) and duration (hours/outage). The program also calculates the need for initiating Emergency Operating Procedures (EOPs), expressed in days/year (see Section 3.5.3).

In addition to calculating the expected values for the reliability indices, MARS also produces probability distributions that show the actual yearly variations in reliability that the NYCA could be expected to experience.

In determining the reliability of the NYCA there are several types of randomly occurring events that must be taken into consideration. Among these are the forced outages of generating units and transmission capacity. Monte Carlo simulation models the effects of such random events. Deviations from the forecasted loads are captured by the use of a load forecast uncertainty model.

Monte Carlo simulation approaches can be categorized as “non-sequential” and “sequential”. A non-sequential simulation process does not move through time chronologically or sequentially, but rather considers each hour to be independent of every other hour. Because of this, non-sequential simulation cannot accurately model issues that involve time correlations, such as

maintenance outages, and cannot be used to calculate time-related indices such as frequency and duration.

A sequential Monte Carlo simulation, the approach used by the MARS program, steps through the year chronologically, recognizing the fact that the status of a piece of equipment is not independent of its status in adjacent hours. Equipment forced outages are modeled by taking the equipment out of service for contiguous hours, with the length of the outage period being determined from the equipment's mean time to repair. The sequential simulation can model issues of concern that involve time correlations, and can be used to calculate indices such as frequency and duration. It also models transfer limitations between individual areas.

Because the MARS Program is based on a sequential Monte Carlo simulation, it uses state transition rates, rather than state probabilities, to describe the random forced outages of the thermal units. State probabilities give the probability of a unit being in a given capacity state at any particular time, and can be used if one assumes that the unit's capacity state for a given hour is independent of its state at any other hour. Sequential Monte Carlo simulation recognizes the fact that a unit's capacity state in a given hours is dependent on a given state in previous hours and influences its state in future hours. It thus requires additional information that is contained in the transition rate data.

If an updated MARS software version becomes available by June 1, prior to the initiation of an IRM Study, ICS should consider its use for conducting the study. The decision to select a new MARS version depends on desirable improvements in the reliability calculation process or correction of program errors in the new version. If there is decision to utilize a new MARS version, it must be tested and benchmarked by the NYISO to ensure that it produces acceptable results. Such tests normally compare results for reasonableness with study results from a previous MARS version using the same assumptions. If a new MARS version becomes available after commencement of an IRM Study, it may be considered for use for the following IRM study.

### **3.3 NYCA Zones and Outside World Representation**

Figure 3-1 depicts the NYCA Zones and Outside World Areas Representation in MARS.

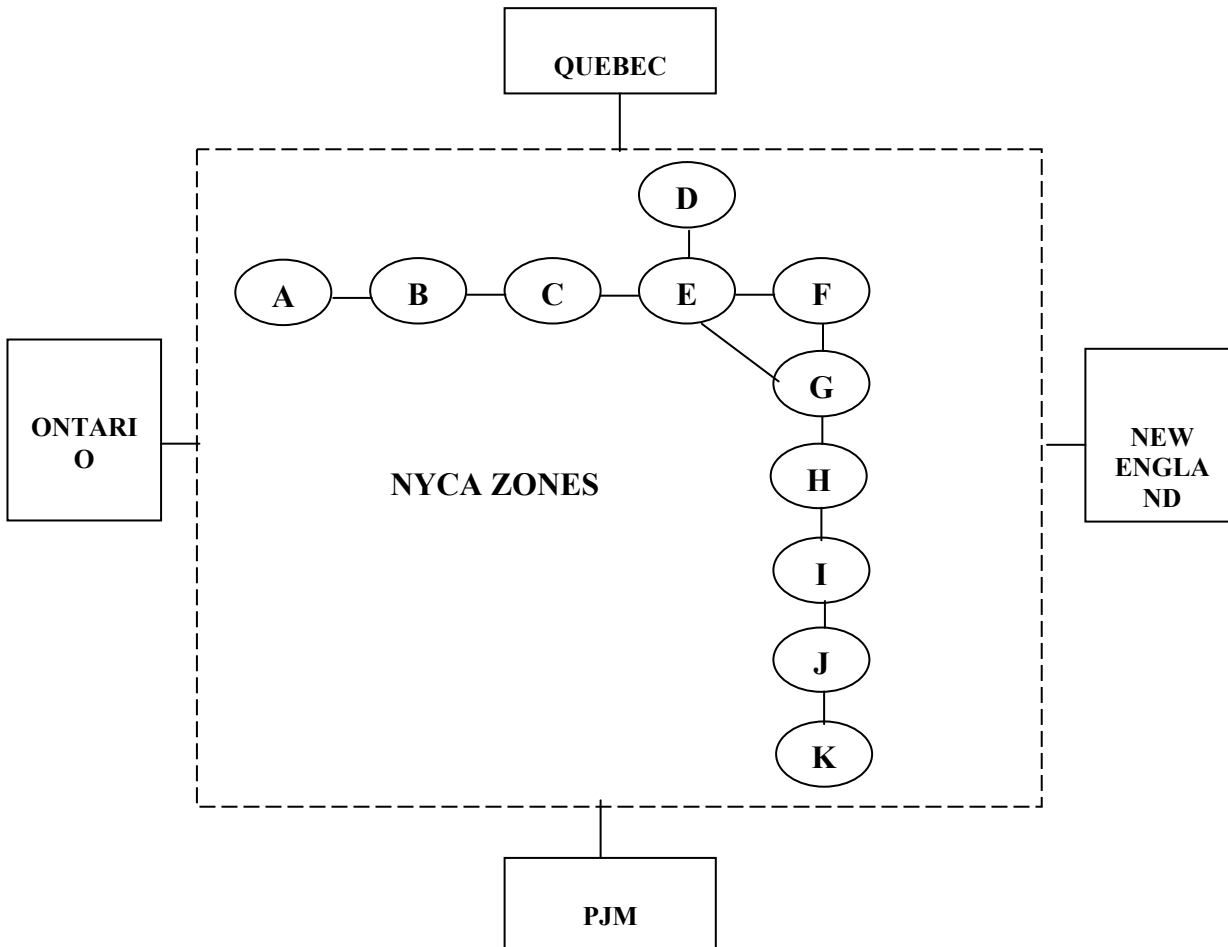

**Figure 3-1: Simplified MARS Representation of NYCA Zones & Outside World Areas**

### 3.4 Conduct of the MARS Analysis

The base case is developed by starting with the previous year’s base case and inputting base case changes one parameter at a time. The LOLE results of each of these pre-base case simulations are reviewed to confirm that the reliability impact of the change is reasonable and explainable.

#### 3.4.1 Unified Method for Establishing IRM Requirements

The procedure utilized for establishing NYCA IRM requirements is termed the *Unified Method* because it provides a coordinated approach that is also used by the NYISO for its analysis of Locational Capacity Requirements (LCRs). The Unified Method establishes a graphical relationship between NYCA IRM and the LCRs as depicted in Figure 3-2.

Under this method capacity is removed from zones west of the Central-East interface that have excess capacity when compared to their forecast peaks until a study point IRM is reached. At this point, capacity is shifted from Zones J and K into the same zones as above until the 0.1 LOLE criterion is violated. Doing this at various IRM points yields a curve such as depicted in



Figure 3-2, whereby all points on the curve meet the NYSRC 0.1 days/year LOLE criterion. Furthermore, all LCR “point pairs” for NYC and LI curves along the IRM axis represent a 0.1 LOLE solution for NYCA. Appendix A provides a detailed description of the Unified Method.

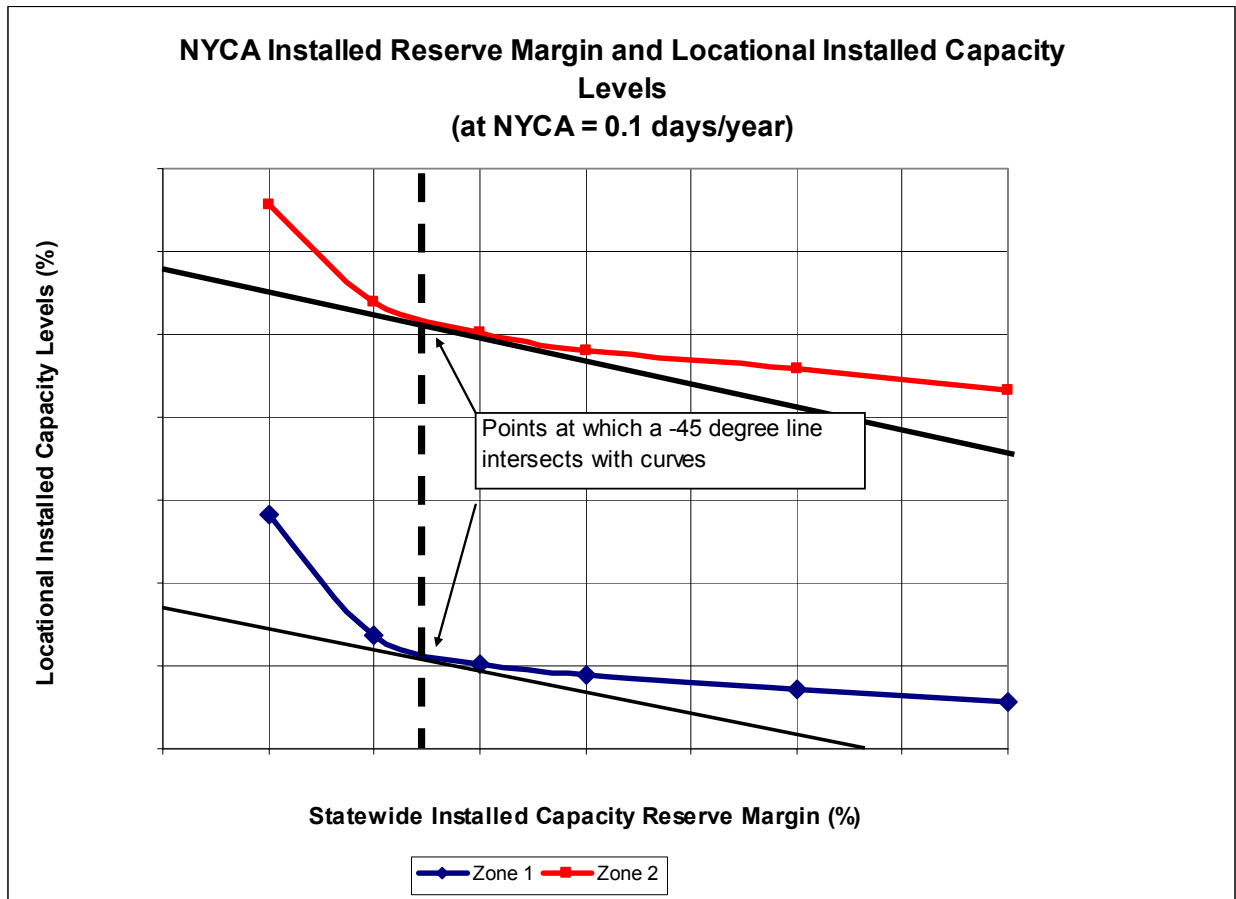

**Figure 3-2: Unified Curve and IRM Anchor Point**

**3.4.2 Base Case IRM Anchoring Methodology**

This method establishes base case NYCA IRM requirements and related minimum LCRs from IRM/LCR curves established by the Unified Method described in Section 3.4.1. The *anchor point* on the curve in Figure 3-2 is selected by applying a tangent of 45 degrees (“Tan 45”) analysis at the bend (or “knee”) of the curve. Points on the curve on either side of the “Tan 45” point may create disproportionate changes in LCR and IRM, since small changes in LCR can introduce larger changes in IRM Requirements and vice versa. Appendix B describes the mathematical analysis for selecting Tan 45 points on the curves. Alternative anchoring methods will be periodically evaluated.

**3.4.3 Sensitivity Analysis**

In addition to running a base case using the input assumptions described below, a number of sensitivity studies are run to show the IRM requirement outcomes for different assumptions. The results of these sensitivity cases are used, along with the base case IRM Study results, by the Executive Committee to establish the final NYCA IRM requirement. In addition, sensitivity analysis provides a mechanism for illustrating “cause and effect” of how certain performance and/or operating parameters can impact reliability.

## **3.5 Input Data and Models**

This section describes the load, capacity, and transmission models that are input to the MARS program for determining NYCA IRM requirements.

### **3.5.1 NYCA Load Model**

The NYCA load model consists of the forecast NYCA and zone peak loads for the next capability year, and load shape and load uncertainty models.

#### **Peak Loads**

The NYISO provides peak and zone load forecasts for the next capability period. The NYISO will provide a preliminary load forecast to ICS for use as part of an initial data base. Following the summer period the NYISO develops a final forecast recognizing actual load conditions experienced during this most recent summer. This forecast should be available by October 1 (see Section 2.2).

#### **Load Shape Model**

The load shape that is input to the MARS program consists of an 8,760 hour chronological model. The appropriate load shape model used for the IRM study is developed by ICS after reviewing historical NYCA load shapes, weather characteristics, and trends from the past ten or more years. From this review, ICS adopts a *typical* year for the analysis after consultation with the NYISO. The load shapes for the 11 zones are hourly aggregates of sub-zone loads. Sub-zone loads are developed by applying appropriate weights to the transmission district load shapes.

#### **Load Forecast Uncertainty Model**

The load forecast uncertainty (LFU) model captures the impacts of weather and economic conditions on future loads. The MARS program calculates the LOLE at each of seven load levels (three loads lower and three loads higher than the forecast peak). Each load level is assigned a probability based on historical data. The MARS program calculates a weighted-average LOLE after evaluating the reliability at all seven load levels. The NYISO develops the load uncertainty model, with review and approval by ICS. Recognizing the unique LFU nature of individual NYCA zones, the LFU model is subdivided into four separate areas: New York City, Long Island, Westchester, and the rest of New York State.

### **3.5.2 NYCA Capacity Model**

The capacity model input to MARS incorporates the several types of resource capacity used to serve load in the NYCA. This section describes how each resource type is modeled in MARS.

#### **Generating Units**

The capacity model includes all NYCA generating units, including new and planned units, as well as units that are physically outside New York State. This model requires the following input data:

*Unit Ratings.* The rating for each generating unit is based on its Dependable Maximum Net Capability (DMNC). The source of DMNC ratings is seasonal tests required by procedures in the NYISO Installed Capacity Manual. The annual NYCA Load and Capacity Report, issued by the NYISO, is the source of those generating units and their ratings included in the capacity model.

*Unit Performance.* Performance data for all generating units in the model includes forced and partial outages, which are modeled by inputting a multi-state outage model that is representative of the “equivalent demand forced outage rate” (EFORd) for each unit represented. The source of this data is outage data collected by the NYISO from generator owners using availability data reporting requirements in the NYISO Installed Capacity Manual. The multi-state model for each unit is derived from the collection of forced and partial outages that occur over the most recent five-year period. The appropriate historic time period should be periodically evaluated. The performance projection for a new or planned unit should be based on NYCA experience with similar units or NERC class-averages for the type and size of the unit.

A second performance parameter to be modeled for each unit is scheduled maintenance. This parameter includes both planned and maintenance outage components. The planned outage component is obtained from the generator owners, and where necessary, extended so that the scheduled maintenance period equals the historical average using the same period used to determine EFORd averages.

*Combustion Turbine and Combined Cycle Units.* Models of combustion turbine and combined cycle deratings due to temperature in excess of DMNC test conditions are developed based on two parameters. The first parameter relates NYCA load to temperature, while the second parameter relates combustion turbine deratings to temperatures above DMNC conditions.

*HydroUnits.* The Niagara and St. Lawrence hydroelectric projects are modeled with a probability capacity model that is based on historical water flows and unit performance. The remaining hydro facilities are represented in MARS with a hydro derate model. This model represents hydro deratings in accordance with recent historical hydro water conditions.

#### **Special Case Resources (SCRs) and Emergency Demand Response Program (EDRP)**

Special Case Resources (SCRs) are loads capable of being interrupted on demand, and distributed generators, rated at 100 kW or higher, that are not visible to the NYISO’s Market Information System. The Emergency Demand Response Program (EDRP) is a separate program that allows registered interruptible loads and standby generators to participate on a voluntary basis and be paid for their ability to restore operating reserves.

The capacity from these programs is based on NYISO projections for the coming capability period. Due to the possibility that some of the potential SCR and EDRP program capacity may not be available during peak periods, NYISO projections are discounted based on previous experience with these programs. Both EDRP and SCR programs are modeled as EOP steps. SCRs, however, because of their obligatory nature, are considered capacity resources in setting the IRM, while EDRP, like other EOP steps such as voltage reductions, are not considered capacity resources.

#### **External Installed Capacity from Contracts**

An input to the study is the amount of NYCA installed capacity that is assumed located outside NYCA. Some of this capacity is grandfathered. The NYISO recommends the amount of external capacity to be used in the base case based on projections for the coming capability period and NYISO Installed Capacity Manual procedures.

#### **Sales**

The NYISO recommends to ICS the inter-area capacity transactions to be modeled in the study.

### Unforced Capacity Deliverability Rights (UDR)

UDR's are capacity rights that allow the holder/owner to receive the Locational Capacity Benefit derived by the NYCA from the addition of a new incremental controllable transmission project that provides a transmission interface to a NYCA locality or zone. The owner/holder of these UDR facility rights must designate how they will be treated by the NYSRC & NYISO in the NYCA IRM and LCR studies, in accordance with the time schedule specified in the NYISO ICAP Manual. The NYISO calculates the actual UDR award based on the transfer capability of the facility and other data.

The holder/owner of the UDR facility currently has the option on an annual basis of selecting the MW quantity of UDR's (ICAP) it plans on utilizing for capacity contracts over its controllable line which counts towards meeting locational and installed capacity requirements, with any remaining capability on the controllable line used to support emergency assistance.

#### **3.5.3 Emergency Operating Procedures (EOPs)**

The NYISO initiates emergency steps when its operating reserve levels approach critical levels. Such EOPs are modeled in IRM studies. The EOP steps consist of those load control and generation supplements that can be implemented before load must be disconnected due to capacity shortages. Load control measures include implementation of SCR and EDRP programs, public appeals to reduce demand, and voltage reduction. Generation supplements could include emergency purchases and cutting operating reserves. The benefit from each of these emergency steps can either be expressed as a percentage of load or in MW. The NYISO recommends to ICS the EOP steps and related capacity values to be represented in the base case, based on operating experience with these measures.

#### **3.5.4 Transmission System Model**

The transmission system is modeled through emergency transfer limits in the interfaces between pairs of NYCA zones, or between NYCA zones and Outside World Areas. These emergency transfer limits are developed in accordance with NYSRC Reliability Rules E-R1, 2 and 3, Thermal, Voltage and Stability Assessments, respectively. The transfer limits are specified for each direction of the interface. Forced outage rates on cable interfaces in southeast New York are modeled in the same manner as generating unit outages, through the use of transition rates. These outage rates are determined and provided by the transmission owners. Certain interfaces are grouped to reflect the maximum simultaneous flow through these interfaces. The NYISO updates the transmission system model annually in accordance with the IRM database schedule in Section 2.2.

#### **3.5.5 Locational Capacity Requirements**

The MARS model used in the IRM study provides an assessment of the adequacy of the NYCA transmission system to deliver energy from one zone to another for meeting load requirements. Previous studies have identified transmission constraints into certain zones that could impact the LOLE of these zones, as well as the statewide LOLE. To minimize these potential LOLE impacts and to ensure that sufficient energy and capacity are available in that zone and that NYSRC Reliability Rules are met these zones require a minimum portion of their NYCA ICAP requirements to be electrically located within the zone, (i.e., locational ICAP). Locational ICAP

requirements are currently applicable to two transmission constrained zones, New York City and Long Island, and are normally expressed as a percentage of each zone's annual peak load.

These locational ICAP requirements, recognized by NYSRC Reliability Rule A-R2 and established by the NYISO in accordance with the NYSRC/NYISO Agreement and the NYISO's tariff, supplement the statewide IRM requirement. The Locational Installed Capacity Requirements Study performed by NYISO determines LSEs requirements for affected zones. As with the IRM Study, the NYISO utilizes the Unified Method for these analyses (see Section 3.4.1) while using nominally the same data base. Differences between these databases, if any, are described in the annual NYISO Locational Installed Capacity Study in accordance with NYSRC Reliability Rules A-R1 and A-R2.

### **3.5.6 Outside World Area Load and Capacity Models**

The reliability of NYCA depends on a large extent on emergency assistance from the Outside World Areas in NPCC and PJM, based on reserve sharing agreements. Therefore, load and capacity models of the Outside World Areas are represented in the MARS analyses. The load and capacity models for New England, PJM, Ontario, and Quebec are based on data received from the Outside World Areas, as well as NPCC sources.

The primary consideration for developing the final load and capacity models for the Outside World Areas is to avoid overdependence on the Outside World Areas for emergency capacity support. For this purpose, a rule is applied whereby an Outside World Area's LOLE cannot be lower than its own LOLE criterion, its isolated LOLE cannot be lower than that of the NYCA, and its IRM can be no higher than that Area's minimum requirement. Another consideration for developing models for the Outside World Areas is to recognize internal transmission constraints within the Outside World Areas that may limit emergency assistance to the NYCA. This recognition is considered either explicitly, or through direct multi-area modeling providing there is adequate data available to accurately model transmission interfaces and load areas within these Outside World Areas.

As with the NYCA, an appropriate historical year is chosen for selecting the Outside World Area load shapes. This decision should depend on what year is chosen to represent NYCA's load shape, review of the years chosen by NPCC and PJM for their studies, and other factors. In order to avoid overdependence from emergency assistance from Outside World Areas, the day of an Outside World Area's highest and second and third highest summer loads should be specified in the load model to match the same load sequence as that of NYCA.

### **3.5.7 Data Base Accuracy**

It is critical that the database used for IRM studies undergo sufficient review to ensure its accuracy. To accomplish this objective, a task force consisting of NYISO staff, ICS members, and General Electric representatives is formed to review the database. PLACE-HOLDER [NOTE: THE NYSRC HAS REQUESTED THE NYISO TO PROVIDE NYSRC REPRESENTATIVES ACCESS TO THE IRM STUDY DATA BASE, SUBJECT TO APPROPRIATE CONFIDENTIALLY PROTECTIONS, TO HELP ENSURE ACCURACY. THE NYSRC REQUEST, WHICH THIS SECTION DEPENDS ON, IS PENDING.]

### **3.6 Data Base Confidentiality**

**A confidentially agreement is in place to protect market sensitive data and data confidentially. FERC Order 666 Code of Conduct rules apply to NYSRC representative with access to IRM Data Base. From time to time changes in the confidentially agreement may be made.**

#### **Section 4: Responsibilities**

This section describes the responsibilities for providing and developing input data and modeling assumptions, conducting the NYCA IRM studies, and establishing the required IRM as described in Section 3. There are four entities having such responsibilities: ICS, Transmission Owners, NYISO, and the NYSRC Executive Committee.

#### **4.1 Installed Capacity Subcommittee**

The ICS has the overall responsibility of managing studies and preparing reports for establishing NYCA installed capacity requirements. Specific responsibilities include:

- Develop and approve all modeling and database assumptions to be used in the reliability calculation process. These assumptions include load models, representation of NYPA generating units and other types of resource capacity, emergency operating procedures, transmission representation, and Outside World Area models (see Section 3.5).
- Approve the version of the MARS program to be used for the study (see Section 3.2).
- Manage conduct of MARS cases for developing the final base case, including benchmarking requirements.
- Specify sensitivity tests to be run (see Section 3.4.2).
- Together with NYISO staff, review and ensure database accuracy (see Section 3.5.7).
- Ensure that the timeline requirements in Section 2.2 are met.
- Arrange for supplemental computer facilities as needed.
- Prepare status reports and the IRM Study for NYSRC Executive Committee review.
- Coordinate above activities with NYISO staff.

#### **4.2 NYISO**

The NYSRC relies on the NYISO to provide sufficient technical and computer support for the IRM Study effort. The basis for this support is provided in the NYISO/NYSRC Agreement. The NYISO leases the MARS computer program used for the reliability calculation studies. The NYISO utilizes the same program and NYSRC assumptions from the IRM Study for its own study of LSE locational capacity requirements.

- Conduct MARS studies for the IRM Study as requested by ICS.
- Develop load, capacity, transmission, and EOP models and supporting data for consideration by ICS for use in the IRM study. This information should be provided to ICS so as to allow the timeline requirements in Section 2.2 to be met. The NYISO should make recommendations to ICS concerning the application of these models in the IRM Study.

- Together with ICS, review and ensure database accuracy.
- Benchmark new versions of MARS.
- Obtain technical support for the application of MARS for IRM studies from General Electric as required.

### **4.3 Market Participants**

Market Participants are knowledgeable concerning load information, planned resource capacity additions, and how transmission should be represented in IRM studies. Market Participants have the responsibility to provide such information to the NYISO for use in the IRM studies.

### **4.4 NYSRC Executive Committee**

The NYSRC Executive Committee has the responsibility of approving the final IRM requirements for the next capability year.

- Review and approve data and modeling assumptions for use in IRM Study.
- Review and approve final IRM Study prepared by ICS.
- Establish and approve the NYCA IRM requirement for the next capability year. This decision should consider base case and sensitivity case results shown in the technical IRM report, as well as considering other issues that may impact NYCA IRM requirements.
- To the extent practicable, ensure that the schedule for the above approvals allow that the timeline requirements in Section 2.2 are met.
- Notify the NYISO of the NYCA IRM requirements. Meet with NYISO management as required to review IRM Study results.
- Make IRM requirement study results available to state and federal regulatory agencies and to the general public.

**NEW**  
**APPENDIX A**  
**Unified Methodology Description**

## **1.0 Introduction**

- 1.1. Appendix A describes a procedure to develop the statewide Installed Reserve Margin (IRM) versus Minimum Locational Capacity Requirements (LCRs) curves. Within the New York Control Area (NYCA) there are currently two zones identified as localities to which this procedure would apply. They are the New York City and Long Island zones.

## **2.0 Initial Conditions**

- 2.1. A Multi-Area Reliability Simulation (MARS) base case database exists for the upcoming capability year.
- 2.2. Localities in the NYCA have been identified.
- 2.3. Any capacities that have been added, removed, or shifted as a result of arriving at a base case for the IRM study should be reset to the “as found” case for purposes of this procedure. This procedure should start with ‘as forecast’ capacities, and ‘as forecast’ loads.

## **3.0 Procedure for setting starting capacities**

- 3.1. Add or remove capacity from zones West of the Total East Interface that have excess capacity reserves (capacity rich zones), proportional to their existing excess capacity, until the statewide capacity to peak load ratio equals a desired IRM study point.
  - 3.1.1. The recommended method for adding or removing capacity in the MARS model, in this case, is to add or remove an amount of capacity proportional to the existing capacity of each unit in the subject zone.
    - 3.1.1.1. This can be accomplished using the MARS table - ‘UNT\_MXCP’.
  - 3.1.2. Verify that the correct amount of capacity was added/removed in the above step by performing a single iteration of the model and checking total capacity from the 07 output file.
  - 3.1.3. Verify that the correct IRM study point was reached using the above information. Repeat step 3.1 as necessary until the study point is achieved.
- 3.2. Simulate the year for as many replications as needed until the LOLE converges within a standard error of 0.05 days/year. (Note: Based on previous studies the NYCA model converges in around 1500 replications)



3.2.1. Note the total NYCA LOLE risk and the risk in all NYCA zones.

#### **4.0 Find the initial target capacity for the first study locality**

Note that the initial target capacity is the maximum capacity that can be added/removed from the localities before the NYCA LOLE risk is 0.1 days/year.

- 4.1. Using the case from Section 3.2, add or remove a trial amount of capacity from the first study locality using the method expressed in section 3.1.
- 4.2. If capacity is removed in the above step, add the same amount of capacity to the capacity rich zones identified above in Section 3.1, proportional to their existing excess capacity. If capacity was added in the above step, remove the same amount of capacity to the capacity rich zones identified above in Section 3.1. Performing this step has the effect of shifting capacity from/to the localities.
- 4.3. Simulate the year for as many replications as needed until the LOLE converges within a standard error of 0.05 days/year.
- 4.4. If the NYCA system LOLE is below 0.100, remove capacity from the subject locality (adding it to the capacity rich zones) and repeat the steps in Sections 4.1 through 4.3, until the NYCA system LOLE approaches 0.100 days/year.
- 4.5. If the NYCA system LOLE is above the 0.100, add capacity from the subject locality (subtracting it the capacity rich zones) and repeat the steps in Sections 4.1 through 4.3, until the NYCA system LOLE approaches 0.100 days/year.
- 4.6. Once the LOLE has approached 0.100 days/year within a standard error of 0.05 days/year, note the amount of capacity shifted. This is the initial target capacity.
  - 4.6.1. If 0.100 LOLE cannot be achieved by shifting capacity to or from the subject locality, the study point is not solvable and should be discarded.
- 4.7. Repeat the steps in Section 4.1 through 4.6 for a second locality and note the amount of capacity shifted as the initial target capacity for that locality.

#### **5.0 Find the initial target capacities for other localities**

- 5.1. Prior to proceeding to the next step, reset any capacities shifted during the above step.
- 5.2. Repeat step 4 for each identified locality and note the amount of capacity shifted as the initial target capacity for that zone

#### **6.0 Determine the capacity multiplier for each locality**

- 6.1. The capacity multiplier is the target capacity of the locality in question divided by the sum of all the target capacities. For example, suppose there are only two localities. From zone one, the LOLE approaches 0.100 when 300 MW are removed. From zone two, the LOLE approaches 0.100 when 100 MW are removed. The capacity multiplier for zone one is  $300/400$  or 0.75, while the capacity multiplier for zone two is  $100/400$  or 0.25.

## **7.0 Find the final adjusted capacities**

- 7.1. Prior to proceeding to the next step, reset any capacities added or removed during the above step, i.e., use the case from Section 3.2.
- 7.2. Estimate a total amount of (trial) perfect capacity to be added or removed from the two localities.
  - 7.2.1. Use the capacity multipliers to divide the above trial capacity between the two localities.
- 7.3. If capacity is removed in the above step, add the same amount of capacity to the capacity rich zones identified above in Section 3.1, proportional to their existing excess capacity. If capacity was added in the above step, remove the same amount of capacity to the capacity rich zones identified above in Section 3.1.
- 7.4. Simulate the year for as many replications as needed until the LOLE converges within a standard error of 0.05 days/year.
- 7.5. If the NYCA system LOLE is below 0.100, remove more capacity from the locality zones (adding it to the capacity rich zones) and repeat the steps in Sections 7.1 through 7.5, until the NYCA system LOLE approaches 0.100 days/year.
- 7.6. If the NYCA system LOLE is above the 0.100, remove less capacity from the locality zones (adding less to the capacity rich zones) and repeat the steps in Sections 7.1 through 7.5, until the NYCA system LOLE approaches 0.100 days/year.
- 7.7. Once the LOLE reaches 0.100 days/year within a standard error of 0.05 days/year, note the amount of capacity removed from each identified locality. These are the final adjusted capacities.

## **8.0 Determining the minimum locational ICAP requirements (LCRs)**

- 8.1. For each identified locality, divide its final adjusted capacity by its peak load forecast. This, expressed as a percentage, is its locational ICAP requirement (LCR) for the IRM point being studied.

## **9.0 Determining more points on the LCR-IRM curve**

- 9.1. Repeat the steps in Sections 3 through 8 for each IRM point desired.

## **10.0 The LCR-IRM curves**

- 10.1. Graph the LCR-IRM curves for the points studied above.

**APPENDIX B (NEW)**  
**Selection of TAN 45 Points on the IRM/LCR Curves**  
**Established by the Unified Methodology**

The IRM Anchoring Method identifies the NYCA IRM Requirements and related MLCR from IRM/LCR curves established by the Unified Methodology. The *anchor point* on the curve is selected by applying a tangent of 45 degrees (“Tan 45”) analysis at the bend (or “knee”) of the curve as shown on Figure B-1 below. Based on these curves, extreme points on the curve on either side of the “Tan 45” point may create disproportionate changes in LCR and IRM, since small changes in LCR can introduce larger changes in IRM Requirements and vice versa.

A regression analysis is utilized to best fit the IRM/LCR curves and determine the TAN45 point, rather than a visual inspection of the curves. The best curve fit is a multi-order polynomial with an  $R^2$  of 1, which indicates a “perfect” fit.

Using this second order polynomial fit analysis, the anchor points are developed such that a single IRM is determined to satisfy reliability criteria for both locational zones.

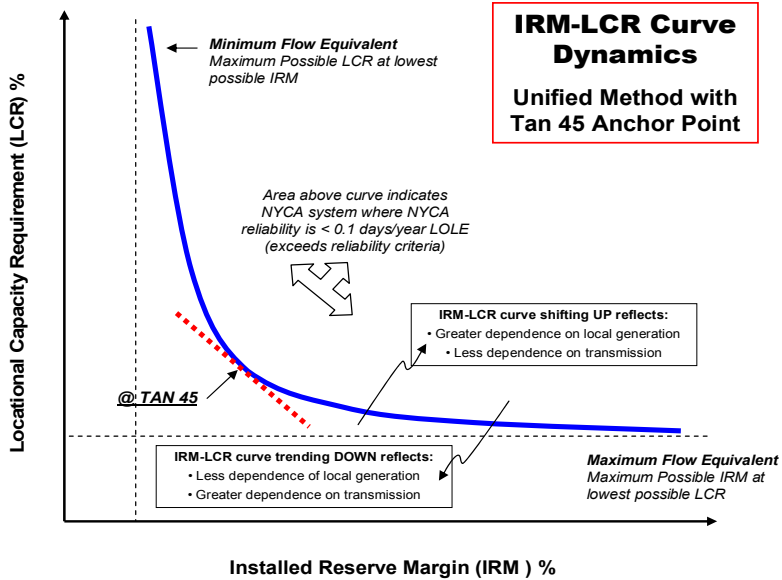

**Figure B-1: IRM-LCR Unified Method Curve Dynamics with Tan 45 Anchor Point**