



# NYSRC Distributed Energy Resources Workshop Summary

Roger Clayton, NYSRC Chairman

Presentation to NPCC Governmental/Regulatory Affairs Advisory Group

Toronto, Canada. December 4, 2018

# NYSRC DER Workshop Agenda – November 7, 2018



***Workshop Objective – To raise awareness of possible adverse reliability impacts of widespread DER penetration***

- 1. Introduction**
- 2. Regulatory Status**
  - National
  - Regional
  - New York
- 3. DER Penetration into NYCA (current & future)**
  - Retail (net metered)
  - Wholesale (REV DSP)
  - Wholesale (NYISO queue)
- 4. Technical Considerations**
  - Fundamentals
  - Operations
  - Planning
- 5. Panel Discussion**

All presentations available on the NYSRC home page: <http://www.nysrc.org/>



# DER Regulatory Status

## FERC

- Order 841 – Electric Storage (February 2018)
- Staff Report - DER Technical Considerations for the BPS (February 2018)
- Technical Conference – DER Technical Considerations for the BPS (April 2018)

## IEEE

- IEEE Standard 1547-2018 - Interconnection and Interoperability of Distributed Energy Resources with Associated Electric Power Systems Interfaces
- Technical Report - Impact of Inverter Based Generation on BPS Dynamics & Short-Circuit Performance (July 2018)

## NERC

- Standard PRC-024-2 — Generator Frequency and Voltage Protective Relay Settings (July 2016)
- Reliability Guideline – Modeling DER in Dynamic Load Models (December 2016)
- Report – Connection Modeling & Reliability Considerations (February 2017)
- Reliability Guideline – DER Modeling (September 2017)
- Report - 900 MW Fault Induced Solar Photovoltaic Resource Interruption Disturbance (February 2018)
- Technical Brief – Data Collection Recommendations (March 2018)
- Industry Recommendation – Loss of Solar Resources during Transmission Disturbances due to Inverter Settings (May 2018)
- Reliability Guideline – BPS Connected Inverter Based Resource Performance (September 2018)
- Working Group - System Planning for Impact of DER (SPIDER WG) (September 2018)

# DER Regulatory Status



## NPCC

- Report on the Impact of DER (March 2016)
- Report on the Effect of Lower System Inertia on Transmission Reliability due to Inverter Based Generation (December 2016)
- UFLS Study on Sensitivity to DER
- On-Going
  - Development of guidelines & practices to address DER modeling in planning studies
  - Examine potential regional approach to DER modeling
  - Study potential reliability impacts of DER

## DER NYCA Penetration – Retail (Liz Grisaru-NYS DPS)



### REV Targets:

- 40% reduction in GHG from 1990 levels
- 50% renewables  $\leq$  2030
- 600E12 Btu increase in EE from 1990 levels
- 1.5 GW energy storage  $\leq$  2025
- NY Sun incentive program 3 GW  $\leq$  2023

### New York Standardized Interconnection Requirements (SIR) apply to:

- New DG facilities sized up to 5 MW AC nameplate aggregated on the customer side of the PCC;
- New energy storage, stand alone or combined with DG, also limited to 5 MW
- Modifications to an existing facility that affect the interface at the PCC

# DER NYCA Penetration – Retail (Liz Grisaru-NYS DPS)



## Number of PV Projects in-service <= August 2018

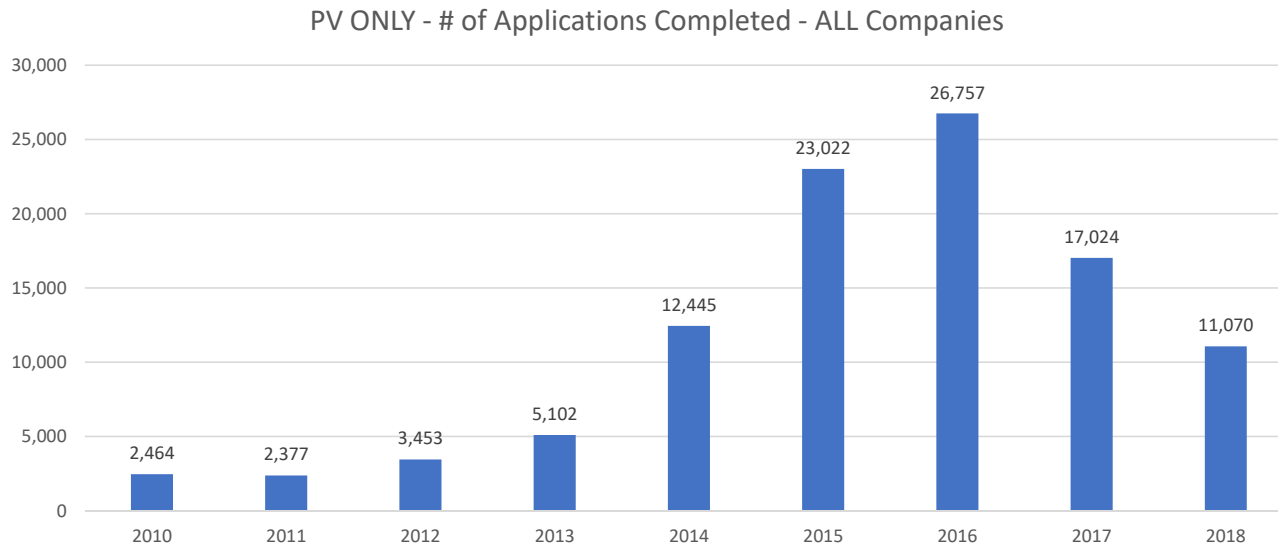

New York State DPS - SIR Interconnection Queue Summary:

<http://www3.dps.ny.gov/W/PSCWeb.nsf/96f0fec0b45a3c6485257688006a701a/286d2c179e9a5a8385257fbf003f1f7e/>

# DER NYCA Penetration – Retail (Liz Grisaru-NYS DPS)



Net Capacity (KW) of PV Projects in Service <= August 2018

Company	PV ONLY - Completed by kW Range (kW) to Date					Total
	0-50	50-300	300-1000	1000-2000	2000-5000	
National Grid	149,113	49,594	20,154	135,636	-	354,496
Con Edison	140,880	33,711	26,109	6,312	-	207,012
Central Hudson	62,618	6,259	6,094	6,295	-	81,266
Orange and Rockland	48,226	3,437	2,653	16,544	-	70,859
NYSEG	60,512	12,477	8,718	37,502	-	119,208
RGE	11,138	4,307	6,366	22,498	-	44,310
PSEG	299,930	27,241	19,301	13,316	8,000	367,788
<b>Total</b>	<b>772,416</b>	<b>137,025</b>	<b>89,395</b>	<b>238,102</b>	<b>8,000</b>	<b>1,244,938</b>

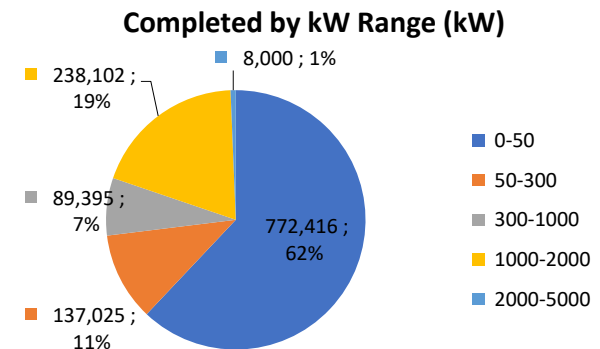

New York State DPS - SIR Interconnection Queue Summary:

<http://www3.dps.ny.gov/W/PSCWeb.nsf/96f0fec0b45a3c6485257688006a701a/286d2c179e9a5a8385257fbf003f1f7e/>

## DER NYCA Penetration – Wholesale (Paul Haering-Central Hudson)



### Interconnected Projects & Queue Size

- Queue Coordination is critical as interconnection queues continues to grow
- Besides PV and Wind, Battery storage resources proposals are becoming significant

	In Service (MW)	In Service (# of Projects)	In Queue (MW)	In Queue (# of Projects)
NYISO	1,884	24	15,318	140
NYS SIR	1,362	109,054	1,849	13,310
Total	3,246	109,078	17,167	13,450



# DER NYCA Penetration – Wholesale & Retail (NYISO 2018 Gold Book)



## Reforming the Energy Vision Programs as of 2018

- Distributed Energy Resources (DER)
  - Inverter connected solar & wind resources
  - NYISO 2018 Gold Book nameplate total installed capacity before the meter
    - Wind 1739 MW  $\leq$ 2018,  $\sim$ 3,300 MW  $\leq$ 2025 (Queue estimate)
    - Solar 31 MW  $\leq$ 2018,  $\sim$ 8,900 MW  $\leq$ 2025 (Queue estimate)
  - NYISO 2018 Gold Book nameplate total installed capacity behind the meter
    - Non-solar 213 MW  $\leq$ 2018,  $\sim$ 422 MW  $\leq$ 2025
    - Solar 1,504 MW  $\leq$ 2018,  $\sim$ 3,313 MW  $\leq$ 2025

# DER NYCA Penetration – Wholesale & Retail (Paul Haering-Central Hudson)



Interconnection study lead and process based on three criteria

- Intended Market (Wholesale or Retail)
- Interconnection Point (Transmission, Distribution FERC or non-FERC jurisdictional)
- Project Size

Intended Market	Interconnection Point *	Project Size	Study Process
Wholesale	NYS Transmission System or Distribution subject to NYISO's OATT Interconnection Procedures**	> 5MW	NYISO
		≤ 5MW	NYISO
	Distribution not subject to NYISO's OATT Interconnection Procedures	> 5MW	Utility
		≤ 5MW	SIR
Retail	NYS Transmission System or Distribution subject to NYISO's OATT Interconnection Procedures	> 5MW	Utility
		≤ 5MW	Utility
	Distribution not subject to NYISO's OATT Interconnection Procedures	> 5MW	Utility
		≤ 5MW	SIR

# DER NYCA Penetration – Wholesale (Paul Haering-Central Hudson)



## SIR Interconnection process

- Coordination of inclusion rules is critical for study work
- Projects are competing for the same interconnection points
- Interconnection procedures are not consistent
  - SIR and Utility procedures require full deliverability (NYISO procedure is a minimum interconnect standard)
- Projects may be dependent on upgrades paid for by developers in other interconnection processes
- No ability to share upgrade costs between Interconnection processes
- In many cases the same project may be venue shopping and have applied through both NYISO and Utility Procedures

# DER NYCA Penetration – Wholesale (Liz Grisaru-NYS DPS)



## Interconnection Working Groups

### Technical

- Technical barriers & new technologies
- Consultants – EPRI & Pterra
- SIR screening
- Islanding Protection
- Monitoring and Control
- Voltage Flicker
- Energy Storage
- Metering Configurations

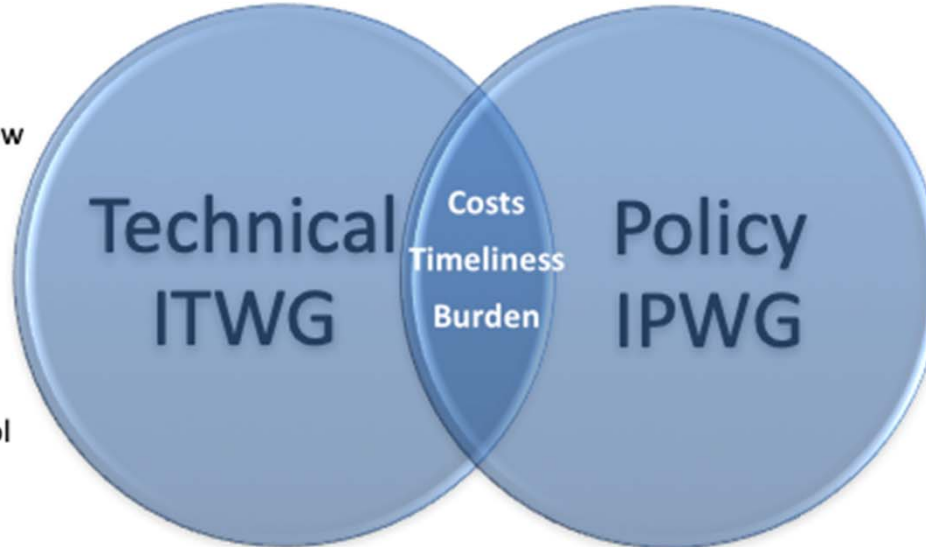

### Policy

- Queue management methodology
- Communication
- Policy interpretation, timelines, and stage gates
- VDER / NEM grandfathering
- Cost allocation

# Technical Considerations – Fundamentals (John Undrill)



## Frequency and Voltage Control in systems with high DER penetration

- The availability and prompt delivery of primary frequency response is critical today
- The timing of delivery will need to be quicker as the fraction of electronically coupled equipment increases
- The frequency sensitivity and voltage sensitivity of loads are as important as the characteristics of generation
- It will be necessary for electronically coupled generation to contribute primary frequency response
- The effects on frequency control of replacing rotating generation with electronically coupled DER are system wide
- The effects on voltage control of replacing direct connected equipment with electronically coupled equipment may be mainly local (but not always so)
- Proper use of primary response of electronically coupled generation can be expected to improve quality of frequency and voltage control

# Technical Considerations – Operations (Vijaya Ganugula-NYISO)



## Integrating DER in Wholesale Markets

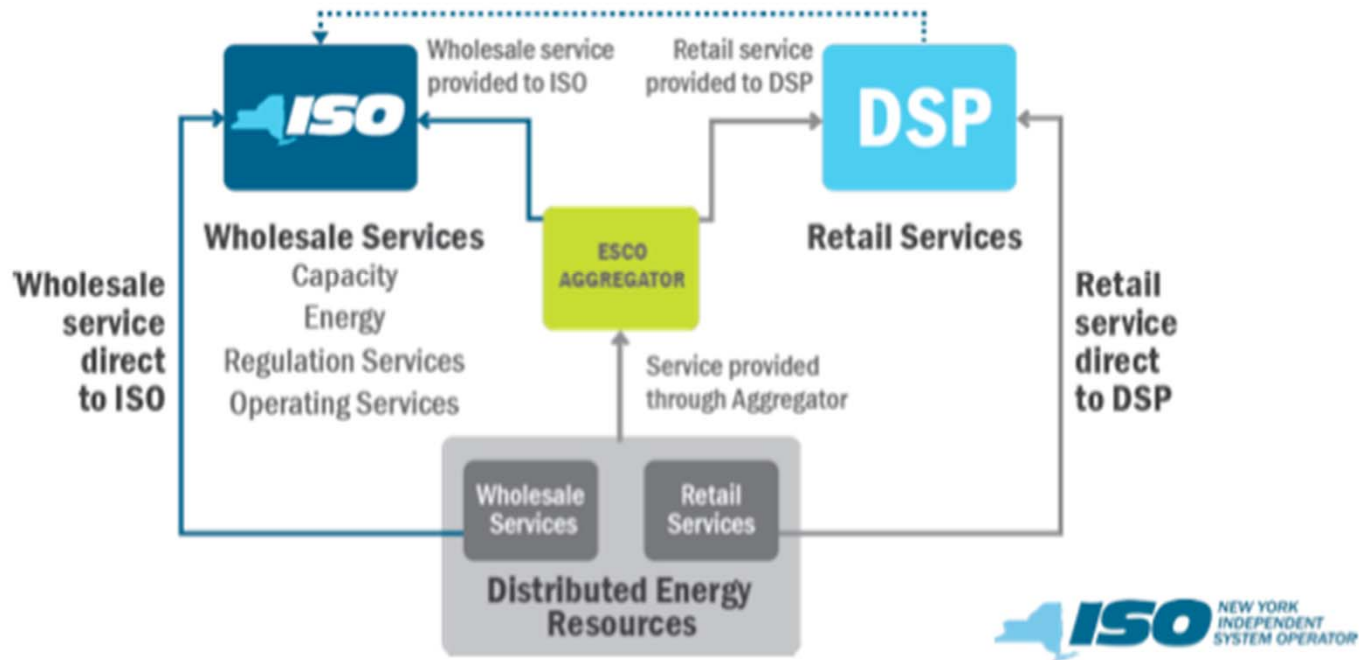

# Technical Considerations – Operations (Vijaya Ganugula-NYISO)



## DER: Additional Operations' Considerations

- **NYISO Operations continues to monitor and evaluate if any additional changes are required to integrate DER:**
  - Regulation requirements
  - Operating reserve requirements
    - Geographical granularity
  - Solar PV forecasting
  - Load forecasting
    - Behind-the-meter (non-wholesale) DER
    - Price responsive load
    - Geographical granularity
  - Transmission security requirements
  - Voltage support requirements
  - Black start requirements
  - Future market design efforts to incent resource flexibility and dispatchability



# Technical Considerations – Planning (Pramila Nirbhavane-NYISO)

## Representation of DER and Composite Load Model

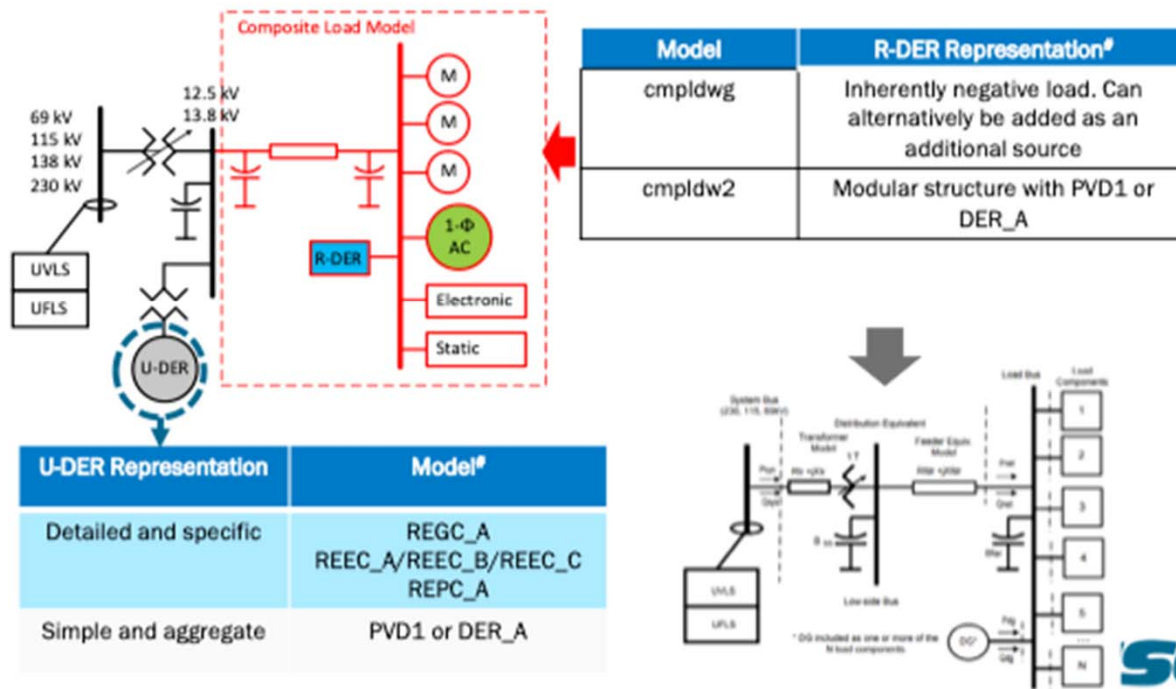



# Technical Considerations – Planning (Pramila Nirbhavane-NYISO)

## Complex Problems of Load Modeling and DER Resources

- ▶ Current practices net DER with loads at the substation level
- ▶ NERC recommends avoiding the netting of DER with loads
  - ▶ This is subject to the accurate DER models available for system modeling
- ▶ All components of the system must be represented in the models, either directly or in an aggregated way, to provide meaningful and accurate simulation results



## Major Workshop Conclusions

- The interconnection of DER devices is already significant and continues apace
- There are significant challenges to the successful integration of DER into the electric power system
  - Resolution of institutional, planning and operational issues for behind the meter & network DER
    - Coordination of planning & operations between the DSP & NYISO
    - Development of appropriate communication requirements, monitoring, supervisory control & standards
    - Development of market rules addressing queue inclusion, gaming & curtailment
  - Development of appropriate DER simulation tools & planning methods
    - Validated DER models for individual DER & DER aggregations
    - Development of integrated transmission & distribution system models
    - Collection of DER performance data