



Interconnection Requirements for Distributed Energy Resources Connected in Parallel with the Central Hudson Electric Delivery System

OCTOBER 2019

Table of Contents

I. DEFINITIONS.....	1
II. INTRODUCTION.....	4
III. APPLICATION PROCESS.....	5
A. Applications ≤ 5 MW	5
B. Applications > 5 MW	5
C. NYISO Interconnection Process	5
D. Additional Documentation Required for Detailed Impact Studies.....	6
1. One Line Diagram	7
2. Description of Operation	7
3. Site Plan	7
4. Interconnection Equipment Data Sheets	8
5. Detailed Specifications of Interconnection Equipment	8
6. Three Line Diagrams	9
7. Control Diagrams	9
8. Written Verification Test Procedure	9
E. Project Management.....	10
F. Service Requirements.....	10
1. Metering Requirements	10
2. New Service Requirements	11
IV. INTERCONNECTION TECHNICAL REQUIREMENTS	12
A. System Design Requirements.....	12
1. General	12
a. Standards, Codes, and Guidelines	12
2. Protection Requirements	13
a. Fail Safe and Redundancy (Primary and Backup Systems)	14
b. Type Tested and Certified Inverters	14
c. Fault Detection on the Central Hudson System	15
3. Control System Requirements	16
4. Effectively Grounded Sources	16

a. Purpose of Effective Grounding	16
b. Requirements of Effective Grounding.....	16
c. Suggested Effective Grounding Methods	17
d. Additional Considerations Specific to Inverter-Based Systems.....	18
5. Phase Balancing	19
6. Power Quality	19
a. Voltage Flicker	19
b. Harmonic Limits	20
c. Limitation of DC Injection	20
7. Specific Requirements for Induction Generators	20
8. Specific Requirements for Synchronous Generators	21
9. Specific Requirements for Inverter-Based DER	21
a. General Inverter	21
b. Requirements for PV systems	22
c. Requirements for Energy Storage Systems	23
d. Future Considerations for Smart Inverters	23
10. AC Visible Disconnect Switch Requirements	24
11. Monitoring & Control	24
a. Summary of Requirements.....	24
b. Monitoring Requirements.....	25
c. Control Requirements	25
B. Utility System Modifications and Upgrades.....	25
1. Constraints Requiring Utility Modifications and Upgrades	26
a. Thermal Overload.....	26
b. Reverse Power Flow	26
c. Operational Contingencies	26
d. Distribution Automation	27
e. Voltage Regulation	28
f. Power Quality	28
g. Protection.....	28
(1) Anti-Islanding Protection.....	28
(2) Substation Overvoltage Protection	29
2. Potential System Upgrades.....	29
a. Distribution.....	29
b. Substation	33
c. Transmission	35
C. System Testing and Operating Requirements.....	36
1. Preliminary Testing.....	36
2. Verification Testing.....	37
a. Minimum Requirements for Verification Testing.....	37
b. Central Hudson Witnessing of Verification Testing.....	38
3. Operations, Maintenance, and Future Testing.....	39
4. Utility Disconnection of Customer DER System	40
V. FUTURE REVISIONS.....	42
A. NYSSIR.....	42

B. NYISO Requirements	42
C. Regulatory Orders	42
D. Industry Standards	42

Figures

Figure 1- Example of a One-Line Diagram: Three Phase Induction Generator	43
Figure 2- Example of a One-Line Diagram: Three Phase Synchronous Generator	45
Figure 3- Example of a One-Line Diagram: Three Phase Inverter-Based DER System.....	47
Figure 4- Example of a Three Line Diagram.....	48
Figure 5- Example of a DC Control Schematic	49
Figure 6- Example of a Functional Test Procedure for the Figure 2 One-Line Diagram	50
Figure 7- Example of a Functional Test Procedure for the Figure 3 One-Line Diagram	57
Figure 8- Examples of Effective Grounding Configurations.....	60
Figure 9- GE Flicker Curve	61
Figure 10- Example of Required Monitoring and Control for Inverter-Based DER Sites without a PCC Recloser	62

Tables

Table 1- Resource Interconnection Study Jurisdiction Table	63
Table 2- Interconnection Equipment Data Sheets	64
Table 3- Identification of “FAIL SAFE” Interconnection Protection Scheme.....	67

I. Definitions

Automatic Load Transfer (ALT): The automated transfer of load to an alternate electrical source following an interruption to the main source.

Central Hudson Gas & Electric (Central Hudson): The owner of the electric grid to which the DER is connected.

Coordinated Electric System Interconnection Review (CESIR): A detailed Impact Study and determination of mitigation requirements and cost estimates that may be required as part of the NYSSIR process for DER applications.

DER Site: The real property where the DER System is located.

DER System: A DER along with all associated equipment that is needed to comply with the requirements in this document, including but not limited to transformers, interrupting devices, protective devices, DER control systems, and utility monitoring and control devices.

Direct Transfer Trip (DTT): A scheme to disconnect a DER System from the grid based on a communications signal from Central Hudson.

Distributed Energy Resource (DER): A source of electric power, including distributed generation, energy storage technologies, or any combination thereof, that is capable of exporting active power to the Central Hudson system. For the purposes of this document, DER includes sources connected to the distribution system as well as the transmission system, where applicable.

Distributed Generation (DG): Generation facilities supplementing on-site load, or non-centralized electric power production facilities.

Distributed Network Protocol 3 (DNP3): A communications protocol used between components in process automation systems.

Distribution Automation (DA): The process by which data from intelligent electronic devices is collected, analyzed, and used to control Central Hudson electrical distribution grid functions.

Distribution Management System (DMS): A software application which monitors and controls the distribution system in conjunction with the system operator.

Energy Management System (EMS): A software application which monitors and controls the transmission system in conjunction with the system operator.

Energy Storage System (ESS): A mechanical, electrical, or electrochemical means to store energy and release electrical energy, and its associated electrical inversion device and control

functions, that may be stand-alone or paired with distributed generation at a point of common coupling.

Federal Energy Regulatory Commission (FERC): The United States federal agency that regulates the transmission and wholesale sale of electricity in interstate commerce.

Impact Study: A study performed by Central Hudson to evaluate the impact of a proposed DER System on the safety and reliability of the electric grid and the quality of power delivered to customers. This includes preliminary and supplemental screening analysis as well as CESIRs under the New York State Standardized Interconnection Requirements.

Institute for Electrical and Electronics Engineers (IEEE): A technical and professional organization that develops standards, guides, and other literature related to, among other topics, the interconnection of DER.

Interconnection Customer: the entity with legal authority to enter into agreements regarding the construction of Distributed Energy Resources, stand-alone Energy Storage Systems, or combined Distributed Energy Resources and Energy Storage System facilities.

Interconnection Online Application Portal (IOAP): Central Hudson's online DER application portal, available from the Central Hudson website.

Nationally Recognized Testing Laboratory (NRTL): An independent laboratory recognized by OSHA to test products to applicable product safety standards.

New York Independent System Operator (NYISO): The agency that operates New York State's bulk electricity grid, administers New York's wholesale electricity markets, and provides comprehensive reliability planning for New York's bulk electricity system.

New York State Reliability Council (NYSRC): An entity that develops, maintains, and updates the Reliability Rules and Compliance Manual for New York's Bulk Power System, which Central Hudson shall comply with.

New York State Standardized Interconnection Requirements (NYSSIR): The New York State Standardized Interconnection Requirements for new DER units with a nameplate capacity of 5 MW or less connected in parallel with a utility's distribution system.

North American Electric Reliability Corporation (NERC): A not-for-profit entity organized under the New Jersey Nonprofit Corporation Act. NERC's mission is to assure the effective and efficient reduction of risks to the reliability and security of the Bulk Electric System. NERC is the FERC designated Electric Reliability Organization (ERO).

Northeast Power Coordinating Council (NPCC): A corporation in the state of New York responsible for promoting and enhancing the reliability of the international, interconnected Bulk Power System in Northeastern North America.

Occupational Safety and Health Administration (OSHA): A government agency that enforces standards to ensure safe conditions for working men and women.

PCC Recloser: An electronic recloser owned by Central Hudson and located at a DER System's PCC.

Point of Common Coupling (PCC): The point of connection between the DER System and the Central Hudson system.

Point of Interconnection (POI): For the purposes of this document, the point where a DER is electrically connected in a DER System, excluding any load present in the DER System. Interconnection Customers applying directly to the NYISO shall utilize the NYISO's definition of POI.

Public Service Commission (PSC): The governing body that regulates the rates and services of Central Hudson.

Supervisory Control and Data Acquisition (SCADA): The hardware and software that monitors and remotely controls equipment on the Central Hudson system.

Utility Grade Device: A device that is constructed to comply with, as a minimum, the most current version of the following standards for non-nuclear facilities:

Standard

ANSI/IEEE C37.90

ANSI/IEEE C37.90.1

Test IEEE C37.90.2

ANSI C37.2

Numbers IEC 255-21-1

IEC 255-22-2

IEC 255-5

Conditions Covered

Usual Service Condition Ratings-

- Current and Voltage Maximum design for all relay AC and DC auxiliary relays
- Make and carry ratings for tripping contacts
- Tripping contacts duty cycle
- Dielectric tests by manufacturer
- Dielectric tests by user

Surge Withstand Capability (SWC) Fast Transient

Radio Frequency Interference

Electric Power System Device Function

Vibration

Electrostatic Discharge

Insulation (Impulse Voltage Withstand)

Value of DER (VDER): A method of compensating DER projects for electricity provided to the grid based on application or payment submission date, technology type, interconnection location, and operational characteristics.

Verification Test: The final testing of a DER System prior to approval for interconnection. The verification test shall demonstrate that all protection and control schemes operate as designed under a variety of grid conditions.

II. Introduction

The purpose of this document is to establish the application process and technical requirements for the interconnection of non-utility-owned generation and energy storage systems seeking to operate in parallel with the Central Hudson electrical system. These requirements are necessary for the safety of the general public and Central Hudson employees, to ensure that Central Hudson and its customers' equipment is protected from damage, and to maintain a high quality of service for all customers.

This document does not apply to backup generators using automatic transfer schemes in which load is transferred between the generator and Central Hudson in a momentary make-before-break operation, provided the duration of paralleling the sources is less than 100 ms. This document also does not apply to electric vehicle installations or systems participating in demand response programs.

This document does not include requirements for protection of the Interconnection Customer's DER System, as this responsibility is solely the Interconnection Customer's. This document also does not include the requirements for microgrid installations or secondary network interconnections.

III. Application Process

There are three different potential application processes for DER systems looking to interconnect to the Central Hudson system. These processes and the criteria determining which of the three a DER developer will follow are outlined below.

A. Applications ≤ 5 MW

For DER Systems up to 5 MW proposing to operate in parallel within the distribution system and not participate in NYISO markets, Central Hudson follows the application process as listed within the NYSSIR. The steps, timelines, and costs associated within the application process are dictated within the NYSSIR and depend on the characteristics of the DER System including but not limited to AC nameplate rating, protective equipment, and the existing distribution circuitry at the point of interconnection.

Visit the Department of Public Service's Distributed Generation website for more information and to download the most current version of the NYSSIR. Application information as well as all applicable forms also can be found on Central Hudson's Distributed Generation website, along with the ability to submit an application online via Central Hudson's Interconnection Online Application Portal (IOAP).

For questions regarding the interconnection application process, refer to contact information listed on Central Hudson's Distributed Generation website.

Note that the NYSSIR application process does not include steps and requirements for completing an application to open a new Central Hudson account. If the applicant is not an existing Central Hudson customer and therefore requires new service for the DER System, refer to [Section III. F. "Service Requirements."](#)

B. Applications > 5 MW

DER with an AC nameplate rating greater than 5 MW that do not qualify for the NYISO Interconnection Process will follow the processes and procedures in [Section III. A. "Applications ≤ 5 MW."](#) but may be subject to additional state and federal procedures. Note that timelines and costs may differ from those described in [Section III. A. "Applications ≤ 5 MW."](#)

C. NYISO Interconnection Process

For DER Systems that meet either of the following requirements:

- Will be connected to a transmission line or transmission substation bus and the Interconnection Customer intends to participate in the NYISO's wholesale markets, or

- Will be connected to an existing FERC jurisdictional for interconnection distribution bus or circuit and the Interconnection Customer intends to participate in the NYISO's wholesale market

the Interconnection Customer is required to submit the interconnection request directly to the NYISO. For information on the appropriate NYISO application process, visit the NYISO's website.

[Table 1](#) defines the relevant jurisdiction for interconnection study/service based on the jurisdictional principles outlined above.

D. Additional Documentation Required for Detailed Impact Studies

The Interconnection Customer is required to provide supporting data on the proposed DER System. This includes all data necessary for Central Hudson to review the installation and to determine if all interconnection requirements have been met.

Equipment shall not be purchased by the Interconnection Customer prior to Central Hudson review and approval. This will enable the Interconnection Customer to develop a design that is not restricted by a previously purchased piece of equipment.

The following information is required to allow Central Hudson to adequately review and assess compliance of the Interconnection Customer's design with Central Hudson's standards. This information shall be submitted by the Interconnection Customer for Central Hudson's review and approval:

- (1) One Line Diagram
- (2) Description of Operation
- (3) Site Plan
- (4) Interconnection Equipment Data Sheets
- (5) Detailed Specifications of Interconnection Equipment
- (6) Three Line Diagrams (AC Relay and Metering Schematics)
- (7) Control Diagrams (DC Control Schematics and PLC Logic Diagrams / Cross Reference Tables)
- (8) Written Verification Test Procedure

Depending on the complexity of the interconnection, Central Hudson may request additional documentation or clarification from the Interconnection Customer. This information also shall be submitted and reviewed by Central Hudson before interconnection approval can be granted.

1. One Line Diagram

The one line diagram describes the interconnection protective system design from the Interconnection Customer's DER System to the Central Hudson electrical system (typically the PCC). The one line diagram should include, as a minimum:

- (a) A lockable, visible break, load break disconnect switch located within 10 feet of the utility meter (if applicable)
- (b) Transformer size(s), voltages, impedance, and connections
- (c) Circuit breaker(s), contactor(s), and switch(es) ratings and types
- (d) Proposed protective function devices identified by ANSI/IEEE Standard C37.2 device numbers
- (e) All interconnection protection function trip and close paths
- (f) Instrument transformers (voltage and current) voltages, connections, ratios, and number
- (g) Generation source – Type, connections, capacity, and power factor
- (h) Grounding resistor(s) and/or reactor(s) – Impedance, type, ratings, and calculations (if applicable)
- (i) AC/DC filtering devices – Size, type, ratings
- (j) All permissive and/or control devices in the trip paths of the interconnection automatic isolation devices

Figures [1](#), [2](#), and [3](#) are included as sample one line diagrams. These one line diagrams are provided strictly as examples and do not address the necessary protection for the Interconnection Customer's equipment.

2. Description of Operation

The Interconnection Customer shall supply a detailed description of the intended operation and operational modes of the generation source, including the method of starting and conditions for closing. Any unusual switching procedures or unique operating conditions also shall be explained.

3. Site Plan

The Interconnection Customer shall submit a detailed site plan showing the following:

- (a) Point of Interconnection (POI) to the existing Central Hudson circuit
- (b) Pole layout
- (c) Equipment layout

- (d) Inverters
- (e) Step up transformer(s)
- (f) Grounding transformer(s), if applicable
- (g) AC disconnect(s)
- (h) Solar arrays
- (i) Proposed conductor size and length between the customer-owned step up transformer and POI

4. Interconnection Equipment Data Sheets

Technical data associated with the interconnection system shall be provided to Central Hudson for review as part of the final design package. This generally includes information regarding generators, inverters, transformers, grounding devices, and filtering devices. [Table 2](#) is included as a sample data sheet which includes information for several of these devices.

5. Detailed Specifications of Interconnection Equipment

Detailed specifications of the equipment associated with the interconnection system shall be provided to Central Hudson for review as part of the final design package. Such information should include:

- (a) Equipment instruction and installation manuals
- (b) Settings and calculations for all devices, including but not limited to relays, grounding transformers, reactors, and open phase detection equipment
- (c) SCADA points list and details of communication method for monitoring and control equipment (where required)

In selecting protective devices, the Interconnection Customer should keep in mind that the following requirements should be met:

- (a) All interconnection protective functions should rely upon non-volatile memory design and include re-settable or retrievable target information.
- (b) Protective relays and controllers should include AC and DC test switches to facilitate verification and periodic testing. Current inputs should have shorting type test switches on either side of each input.
- (c) All interconnection protective devices should be designed and tested to appropriate industry standards and codes. See [Section IV. A. 1. a. “Standards, Codes, and Guidelines”](#) for examples of such standards.

6. Three Line Diagrams

The Interconnection Customer shall submit all three line diagrams (relay and metering schematics) of the equipment associated with the interconnection protective system. Three line diagrams should depict all connections (including device terminal numbers), ratings, and sizes of the Interconnection Customer's:

- (a) Generator source(s)
- (b) Instrument transformers (including polarity designations)
- (c) Transformer(s)
- (d) Interconnection system automatic disconnect equipment (circuit breakers, contactors and switches)
- (e) Generator(s) AC control circuitry
- (f) Interconnection protective devices
- (g) Test switches for interconnection protective devices

The Interconnection Customer is reminded that all information depicted on the three line diagrams shall be accurate and consistent with the design as depicted on the one line diagram. [Figure 4](#) has been included as a sample three line diagram for a small, simple installation.

7. Control Diagrams

The Interconnection Customer shall submit all control diagrams (DC control schematics) of the equipment associated with the interconnection protective system (including device terminal numbers). Control diagrams depict all logic used to control the interconnection protective devices. If programmable logic controllers are used for these functions, a copy of the ladder logic and reference table(s) shall be included. [Figure 5](#) has been included as a sample control diagram for a small, simple installation.

8. Written Verification Test Procedure

The Interconnection Customer shall submit a verification test procedure as described in [Section IV. C. 2. "Verification Testing"](#) for review and acceptance by Central Hudson. Any additional equipment being used to comply with Central Hudson requirements shall be part of the verification test procedure. [Figures 6](#) and [7](#) are included as sample verification test procedures.

E. Project Management

For DER Systems that fall under the NYSSIR as described in [Section III. A. “Applications ≤ 5 MW,”](#) the DER application process is managed through Central Hudson’s Electric Distribution Planning department. Once the Interconnection Customer opts to move forward with their project by providing upgrade payment(s) related to construction upgrades or new service, the applicant will be provided with contact information for a Project Manager. This is typically done after the completion of engineering studies which identify upgrades and the associated estimated costs. The Project Manager is the primary resource for providing DER developers with construction status, including any new service work that may be required, answering questions regarding next steps for construction, as well as providing an estimated construction timeline. The Project Manager will remain the liaison between the Interconnection Customer and all appropriate areas within Central Hudson who may have a role in the construction process. As construction of the DER System nears completion, the Project Manager will inform the appropriate groups within Central Hudson in order to coordinate the timely completion of any upgrades needed on the Central Hudson system. Once the project is ready for final interconnection, the Interconnection Customer can contact the Project Manager to be temporarily energized in order to test that the DER System meets all technical requirements. Final interconnection requests however, shall be submitted using Central Hudson’s IOAP.

For DER Systems that fall outside of the NYSSIR, the Project Manager will be assigned to the project at the beginning stages of interest, including initial project inquiries. The Project Manager will remain the main point of contact throughout the entire process, from initial application submittal through to final construction and interconnection. The Project Manager will work with the Interconnection Customer and all appropriate groups within Central Hudson involved with reviewing the initial application, performing feasibility or impact studies, determining cost estimates for any interconnection upgrades, collecting payments, as well as moving forward with construction upgrades and final interconnection.

To contact Central Hudson’s Electric Distribution Planning Group or the appropriate Project Manager, visit Central Hudson’s Distributed Generation Website.

F. Service Requirements

1. Metering Requirements

For existing Central Hudson customers seeking to install DER behind their meter in order to net-meter, a meter change may be required. The type of meter installed may vary based on VDER eligibility. Note that the DER System may not directly connect to the Central Hudson meter and/or meter pan. For DER applications seeking new service with Central Hudson for the DER System solely (with no native load), Central Hudson requires the following metering configurations:

- DER System less than 300kW: non-demand secondary metered
- DER System 300kW or greater: non-demand primary metered

Per VDER requirements, depending on the type of DER and/or combination of multiple DER projects (for example generation + energy storage system), each DER System may be required to be individually metered, in addition to an overall primary meter. Refer to Central Hudson's *Specifications and Requirements for Electrical Installations* for more information on new service and metering requirements.

DER Systems under jurisdiction of the NYSSIR may be subject to Central Hudson's reactive power tariff if the average power factor measured at the PCC is less than 0.9 (leading or lagging).

2. New Service Requirements

In addition to submitting an interconnection application for review and approval prior to interconnection, new DER Systems are also required to submit an application for new service as part of a separate process. As part of this process, Interconnection Customers shall adhere to Central Hudson's *Specifications and Requirements for Electrical Installations*. Central Hudson's New Service Request website provides customers with the capability to:

- Review instructions and guidelines regarding completing new service requests
- Review Central Hudson's *Specifications and Requirements for Electrical Installations*
- Submit an application for new service online or by mail
- Review a site-ready checklist

New Service construction for primary metered customers typically consists of the following arrangement: a Central Hudson owned take-off pole from the existing distribution circuit, a Central Hudson owned protective device to protect the DER site (either fuses or an electronic recloser), and finally, a primary meter cluster on a customer-owned pole. All other circuitry and equipment downstream from the primary meter is the customer's responsibility, but should be provided for review and approval from Central Hudson. Note that the New Service group will work with the Interconnection Customer to determine the final point of interconnection based on the field conditions as well as taking into consideration the POI analyzed during the Impact Study; however, for operational and reliability purposes it is Central Hudson's policy to install the take-off pole and primary meter as close to the mainline and road as possible.

While DER Systems less than 300kW are secondary metered, when the new service request includes no native load, the Interconnection Customer will be required to procure, install, and own the interconnection step-up transformer as well as secondary service conductor(s). These designs however, shall be reviewed and approved by Central Hudson prior to purchase or installation. Refer to Central Hudson's *Specifications and Requirements for Electrical Installations* for more information on new service and metering requirements.

IV. Interconnection Technical Requirements

A. System Design Requirements

The following design criteria are required for the interconnection of DER Systems to Central Hudson. These criteria serve to ensure safety and power quality on the Central Hudson system due to the interconnection of DER Systems.

1. General

a. Standards, Codes, and Guidelines

It is the Interconnection Customer's responsibility to ensure that their DER System is tested and conforms to all applicable standards, codes, and guidelines including but not limited to:

- (a) IEEE Standard for Interconnection and Interoperability of Distributed Energy Resources with Associated Electric Power Systems Interfaces (IEEE 1547)
- (b) IEEE Recommended Practice for the Analysis of Fluctuating Installations on Power Systems (IEEE 1453)
- (c) Standard for Inverters, Converters, Controllers and Interconnection System Equipment for Use With Distributed Energy Resources (UL 1741)
- (d) IEEE Recommended Practice for Grounding of Industrial and Commercial Power Systems (IEEE 142)
- (e) IEEE Guide for Application of Neutral Grounding in Electrical Utility Systems Supplied by Current-Regulated Sources (IEEE C62.92.6)
- (f) IEEE Recommended Practice and Requirements for Harmonic Control in Electric Power Systems (IEEE 519)
- (g) Measuring relays and protection equipment - Part 26: Electromagnetic compatibility requirements (IEC 60255-26)
- (h) Measuring relays and protection equipment - Part 27: Product safety requirements (IEC 60255-27)
- (i) IEEE Standard Surge Withstand Capability (SWC) Tests for Relays and Relay Systems Associated with Electric Power Apparatus (ANSI C37.90.1)

- (j) IEEE Standard for Withstand Capability of Relay Systems to Radiated Electromagnetic Interference from Transceivers (ANSI C37.90.2)
- (k) IEEE Guide for Protective Relaying of Utility-Consumer Interconnections (IEEE C37.95)
- (l) ANSI Standard for Electric Power Systems and Equipment – Voltage Ratings 60Hz (ANSI C84.1)
- (m) IEEE Recommended Practice for Sizing Lead-Acid Batteries for Stationary Applications (ANSI/IEEE 485)
- (n) IEEE Recommended Practice for Installation Design and Installation of Large Lead Storage Batteries for Generating Stations and Substations (ANSI/IEEE 484)
- (o) IEEE Recommended Practice for Maintenance, Testing, and Replacement of Vented Lead-Acid Batteries for Stationary Applications (ANSI/IEEE 450)
- (p) National Electrical Code (ANSI/NFPA 70)
- (q) National Electrical Safety Code (ANSI C2)
- (r) IEEE Guide for Safety in AC Substation Grounding (IEEE 80)
- (s) Local Ordinances

Upon review, Central Hudson typically applies the latest version of standards and codes. Central Hudson will also apply technical guidelines on a case by case basis.

All DER System wiring shall be inspected by an approved inspection agency. A list of approved inspection agencies can be found on the Central Hudson Website. As of the development of this document, it could be directly found at <https://www.cenhud.com/workingwithus/index>. Proof of compliance (such as an electrical inspection certificate or temporary cut-in card) shall be submitted to Central Hudson prior to the final approval for interconnection.

In addition, for DER Systems interconnected to the transmission system, the Interconnection Customer's system shall be designed, maintained and operated to Central Hudson's *Transmission Planning Criteria* and NYISO (New York Independent System Operator), NYSRC (New York State Reliability Council), NPCC (Northeast Power Coordinating Council) and NERC (North American Electric Reliability Council) standards and criteria, as applicable.

2. Protection Requirements

This section outlines the protection requirements for interconnecting customer-owned DER Systems to the Central Hudson grid.

a. Fail Safe and Redundancy (Primary and Backup Systems)

The Interconnection Customer shall design their interconnection scheme for the same level of safety and reliability that Central Hudson designs into its generation, transmission, and distribution protection. This means that the Interconnection Customer's protection scheme shall be of a "Fail Safe" design. The Interconnection Customer's protection scheme shall be designed to sense any type of fault or system abnormality and isolate the Interconnection Customer's DER System and associated equipment from the Central Hudson system, even when any one of the sensing or interrupting devices has failed to operate.

With the exception of some inverter based DER Systems described in [Section IV. A. 2. b. "Type Tested and Certified Inverters,"](#) a "Fail Safe" design is achieved by utilizing redundant protection and control systems; that is, by duplicating all primary sensing and interrupting functions in a backup protection scheme(s). It is important to provide as much separation between the two systems as is practical. This includes separately fusing primary and back-up protection and control systems, ensuring that all trip paths are not dependent upon correct operation of a single programmable controller, and maintaining no common auxiliary devices (such as lockout relays, programmable controllers, etc.) between the two systems.

If full redundancy of protection and control systems is not applied, the Interconnection Customer's system still may be considered "Fail Safe" if it can be proven that, in the event of any sensor, equipment, or control power failure, all generators and associated equipment will be disconnected from the Central Hudson system (Interconnection Customer's system "fails open"). A UL-1741 certified inverter is an example of equipment that would meet this requirement.

[Table 3](#) is useful to determine if a particular scheme satisfies the "Fail Safe" requirement. Figures [1](#), [2](#), and [3](#) are sample one line diagrams showing typical interconnection protection schemes with a properly filled out [Table 3](#) for each one line diagram. These one line diagrams are given strictly as examples and do not include the necessary protection for the Interconnection Customer's equipment.

b. Type Tested and Certified Inverters

To meet fail safe and redundancy requirements, inverters shall be tested by a Nationally Recognized Testing Laboratory (NRTL) recognized by the United States Occupational Safety and Health Administration (OSHA) in compliance with the most current version of UL 1741 and its Supplement A (SA).

The inverters shall shut down within 2 seconds upon voltage loss of any or all phases on the primary/source side of the interconnection and shall not reconnect for at least 5 minutes after utility voltage and frequency have been restored to nominal per

IEEE 1547 requirements. If inverters can successfully meet these requirements as well as comply with UL 1741 and its Supplement A, fail safe and redundancy requirements are also met as described above in [Section IV. A. 2. a. “Fail Safe & Redundancy.”](#)

For a list of UL 1741 approved inverters, visit the Department of Public Service *Certified Interconnection Equipment List* maintained on the Commission’s website. If a particular inverter is not currently listed on the Commission’s website, documentation such as the certificate indicating compliance with UL 1741 also may be submitted.

Note that while inverters may be UL 1741 certified, depending on system configuration and design, additional protective equipment may be required as a part of the DER System or on the Central Hudson system, typically at the DER site. For example, some inverters may not be able to detect single phase loss on the primary/source side of the step up transformer and will thus require additional Utility Grade protective devices.

c. Fault Detection on the Central Hudson System

The Interconnection Customer's protection scheme shall be designed to detect all abnormal conditions on both the Interconnection Customer’s system and the Central Hudson system. This includes faults and open phase conditions. The Interconnection Customer's generator and all associated equipment shall be automatically disconnected for these conditions.

In order to minimize the impact of electric service interruptions to its customers, Central Hudson operates its distribution system as a single phase system. Per IEEE 1547, all DER Systems interconnecting to the grid are required to detect against loss of any number of phases and disconnect from the Central Hudson system. Depending on the DER’s system design as well as presence or lack of load, voltage backfeed may also occur during a single phase loss. The voltage may exceed ANSI C84.1 allowable limitations under low load conditions and remain undetected by DER protection. If the DER System’s design includes use of protective devices such as an electronic recloser to protect against single phase loss, settings shall be included to protect against voltage backfeed.

Note that it is the Interconnection Customer’s responsibility to ensure that the Interconnection Customer’s equipment is protected against damage caused by faults and abnormal conditions on both the Interconnection Customer's system and on the Central Hudson system.

It is the Interconnection Customer's responsibility to review the protection of their generator and associated devices. Central Hudson is primarily concerned with the protection of Central Hudson-owned equipment, and will not review the protection of the Interconnection Customer's equipment.

3. Control System Requirements

If the Interconnection Customer will utilize a programmable controller for their DER System's control functions, the following points shall be considered:

- (a) To maintain a "Fail Safe" interconnection protection scheme, all trip paths cannot be dependent upon the correct operation of a single programmable controller.
- (b) The Interconnection Customer shall demonstrate that the proposed DER System meets all operating requirements even if the programmable controller experiences a complete or partial loss of control power.
- (c) The speed of operation and design of the programmable controller shall be consistent with accepted protective relaying practices per IEEE C37.95.
- (d) The programmable controller and all associated equipment shall be Utility Grade.

4. Effectively Grounded Sources

a. Purpose of Effective Grounding

The majority of Central Hudson distribution feeders are multi-grounded neutral, four wire systems supplying phase to ground connected loads. During a phase to ground fault on the Central Hudson system, the Interconnection Customer's DER System may become isolated with the fault if the Central Hudson source opens before the Interconnection Customer's source. If the Interconnection Customer's DER System is not effectively grounded while isolated with a phase to ground fault, a neutral shift will occur, causing the Central Hudson system to experience overvoltages of up to 173% of nominal on the unfaulted phases. This overvoltage condition can cause damage to Central Hudson or customer-owned equipment. To avoid possible system overvoltages due to a neutral shift, Central Hudson requires that the Interconnection Customer's DER System interconnect to the grid as an effectively grounded source.

b. Requirements of Effective Grounding

For non-inverter-based DER Systems, Central Hudson follows the definition of effective grounding described in IEEE 142. By this definition, a system is effectively grounded if both of the following are true:

- (a) The ratio of the system's zero sequence reactance to positive sequence reactance (X_0/X_1) is positive and less than three (3), and
- (b) The ratio of the system's zero sequence resistance to positive sequence reactance (R_0/X_1) is positive and less than one (1)

While operating, a customer-owned DER System shall be an effectively grounded source to the Central Hudson system. This is necessary to prevent overvoltages due to neutral shift during ground faults. While not operating, the Interconnection Customer's DER System shall not be a ground source to the Central Hudson system. This is required to avoid the desensitization of Central Hudson's ground fault protection.

During a phase to ground fault on the Central Hudson system, the Interconnection Customer's equipment shall not cause overvoltages greater than 135% of nominal phase to ground voltage on the unfaulted Central Hudson phases.

During an open phase condition on the Central Hudson system, the Interconnection Customer's equipment shall not energize (i.e. backfeed) the open phase.

For inverter-based DER Systems, refer to [Section IV. A. 4. d. "Additional Considerations Specific to Inverter-Based Systems"](#) for further requirements.

c. Suggested Effective Grounding Methods

A DER System may meet effective grounding requirements through its transformer configuration or by use of a grounding transformer, each with or without a neutral reactor.

[Figure 8](#) presents several different methods to effectively ground a DER System via transformer configuration. Other system configurations in which the source is effectively grounded also may be acceptable. The Interconnection Customer shall submit their proposed design for review and approval by Central Hudson.

A grounded wye - grounded wye interconnection transformer with a grounded wye generator may satisfy the requirement of being an effectively grounded source, as it will pass zero-sequence current from the Interconnection Customer source only when the DER is generating. A three-legged core type grounded wye – grounded wye transformer cannot be used; a four-legged or five-legged core type transformer or three single-phase transformers are required to prevent overheating due to zero sequence current circulating through the transformer tank.

For DER technologies that do not supply zero-sequence current (for example, inverter-based DERs), a grounded wye - grounded wye interconnection transformer alone may not satisfy the effective grounding requirement. Central Hudson will review the proposed DER System and, depending on the results, an additional grounding transformer may be required in parallel with the DER equipment to provide zero-sequence current during a ground fault on the Central Hudson system. This grounding transformer shall be appropriately sized to maintain IEEE 142 effective grounding criteria while producing ground current no greater than 10% of the existing ground fault current at the PCC. If the grounding transformer cannot be sized in such a way, the Interconnection Customer shall include provisions to disconnect the grounding transformer at either the high side or the neutral when the DER is not generating. Additional protection, such as open-phase detection settings, may be required with the

inclusion of a grounding transformer. Upon request, Central Hudson will supply the Interconnection Customer with source impedance and fault current levels at the PCC and may assist in the development of open-phase detection settings.

Alternately, the Interconnection Customer may choose to connect their DER System through a grounded wye-delta interconnection transformer with the grounded wye side connected to the Central Hudson system. This transformer configuration is a zero-sequence current source regardless of whether or not the DER is generating. This transformer shall be disconnected when the DER is not generating to prevent the system from being a ground source to the Central Hudson system. In some cases, the installation of an appropriately sized reactor in the neutral of the grounded wye-delta interconnection transformer can limit fault current due to ground faults while satisfying the effective grounding requirement. In this case, it is not required to disconnect the transformer from the Central Hudson system when the DER is not generating. The reactance of this neutral reactor should be selected such that when the upstream distribution protective device is open, the Interconnection Customer's system is still effectively grounded as defined by the impedance ratios in IEEE 142.

A transformer that is delta-connected on the Central Hudson side or ungrounded-wye connected on the Interconnection Customer's side does not provide effective grounding on its own, regardless of the DER technology being used. For these cases, a separate grounding transformer is required. If the grounding transformer cannot be appropriately sized as described above and the interconnection transformer is delta-connected on the Central Hudson side, both the interconnection transformer and the grounding transformer shall be disconnected when the DER is not generating.

Additionally, a delta-connected transformer on the Central Hudson side can backfeed the grid during an open phase condition. If an open phase occurs on the Central Hudson system, the energized delta transformer windings will keep the missing phase energized. This impressed voltage presents a safety concern for anyone who may come in contact with that phase, as well as a power quality concern for other customers connected to that phase. If a customer proposes an interconnection transformer with the ability to backfeed voltage, the Interconnection Customer may be required to install additional protection for open phase detection.

To minimize the effect on Central Hudson's protection, the DER System should be designed to minimize the zero sequence current (i.e. have a larger zero sequence impedance) and still meet the effective grounding requirement.

d. Additional Considerations Specific to Inverter-Based Systems

Conventional generators (i.e. rotating machinery) are classified as constant voltage sources. By contrast, inverters are considered voltage-controlled current sources. Because of this distinction, an inverter-based DER will respond differently to fault conditions than a non-inverter-based DER. Therefore, it is necessary to adjust certain effective grounding criteria for inverter-based DER Systems only.

Many inverters are constructed with a neutral wire that is meant for sensing only, and is not rated to carry fault current. This prevents the inverter from being an effectively grounded source to the Central Hudson system. An interconnection transformer that is a zero sequence current source or an additional grounding transformer may be required for these inverters to meet the effective grounding requirement.

For inverter-based DER Systems with nameplate ratings greater than 50 kW, Central Hudson will evaluate each proposal on a case-by-case basis to determine if a ground source is needed on the Interconnection Customer's system. The Interconnection Customer shall provide Central Hudson with the inverter's positive, negative, and zero sequence impedances if they are available from the manufacturer. If Central Hudson determines that a grounding transformer is required, the Interconnection Customer shall revise their design to include a grounding transformer and resubmit it to Central Hudson for review.

5. Phase Balancing

To reduce the level of power quality impacts as well as maintain proper phase balancing, Central Hudson requires that DER Systems with nameplate ratings greater than 50kW AC be designed as balanced three-phase systems. Designs shall clearly illustrate that the DER System is equally balanced among each of the three-phases. All single phase DER Systems shall meet Central Hudson's phase balancing requirements. This includes ensuring that with the DER System interconnected, Central Hudson can still maintain current phase balancing within 10% between phases.

In addition, it is the Interconnection Customer's responsibility to maintain proper phase balancing, including voltage balance on secondary service lines per the most current version of ANSI C84.1. Any negative impacts that may occur due to system design outside these requirements are the responsibility of the Interconnection Customer. This criterion shall be met with and without the DER System in service.

6. Power Quality

a. Voltage Flicker

Voltage fluctuations on the distribution system can result in observable changes in light. Depending on the severity of the voltage fluctuations, the human eye may perceive these disturbances as flicker, which can result in customer power quality complaints. As a result, all DER Systems operating in parallel to the Central Hudson grid are required to limit flicker emissions during normal operation, as well as during initial connection or upon disconnection.

For DER Systems, thresholds for flicker violations are based on the most current version of the IEEE 1453 Standard. For DER systems that fall within the jurisdiction of the NYSSIR, during impact studies, Central Hudson will calculate the expected flicker emitted by the DER System using methodology described in the New York State Standardized Interconnection Requirements, in order to determine if Central Hudson

system upgrades or DER System modifications are required. The IEEE 1453 Standard states that the DER System shall not have flicker emissions that exceed the planning limit for the applicable voltage range at which the DER is looking to interconnect. DER shall be within planning limits for both the short term and long term flicker emissions.

DER Systems that contain rotating machinery or fall outside of the jurisdiction of the NYSSIR also will be subject to calculations to determine flicker impacts. Maximum permissible thresholds for flicker due to rotating machines are based on the borderline of visibility GE Flicker Curve provided in [Figure 9](#).

b. Harmonic Limits

The maximum harmonic limits for electrical equipment shall be in accordance with the most current version of IEEE 519. The objective of IEEE 519 is to limit the maximum individual frequency voltage harmonic to 3% of the fundamental frequency and the voltage Total Harmonic Distortion (THD) to 5% on the Central Hudson side of the PCC. In addition, DER Systems shall also meet harmonic current distortion limits as described in the most recent version of IEEE 1547.

c. Limitation of DC Injection

Central Hudson limits the level of DC current injection into the grid as it may lead to transformer saturation and other equipment failure. The Interconnection Customer's DER System including all interconnection equipment shall not inject DC current greater than 0.5% of the full rated output current at the point of connection of the DER System.

7. Specific Requirements for Induction Generators

Induction generators require reactive power (VARs) to be supplied from an external source. This reactive power flow can adversely affect the Central Hudson system. Central Hudson may limit the kVA rating of interconnected induction generators due to the adverse effects of reactive power flow and to voltage drop/flicker considerations.

If additional capacitors are required on the Central Hudson system to limit the adverse effects of reactive power flow, the capacitors shall be installed at the Interconnection Customer's expense.

The installation of capacitors for reactive power supply at or near an induction generator may cause the induction machine to become self-excited when isolated from the Central Hudson system. As load approaches generation levels on circuits with induction generators, the probability of accidental self-excitation increases. Under/over frequency and under/over voltage protection schemes, when designed and set properly, can automatically disconnect the Interconnection Customer if this condition occurs.

Induction generators can be connected to the Central Hudson system as a motor and motored up to synchronous speed if the initial voltage drop is acceptable based on IEEE 1453-2015. This standard also applies to induction generators connected at or near

synchronous speed since a voltage dip is present due to inrush magnetizing current. The inrush current is similar in magnitude to starting locked-rotor inrush current, but of shorter duration. The Interconnection Customer should supply calculations to verify that the voltage dip due to the starting is within limitations specified in IEEE 1453-2015.

8. Specific Requirements for Synchronous Generators

Synchronous generators are generally required to operate at unity power factor. Synchronous generators shall include actively controlled power and power factor schemes if not equipped with a Loss of Synchronization protection function.

Synchronous generators shall have automatic synchronizing facilities installed to prevent out-of-phase closing into the Central Hudson system. This requirement may be waived if it can be shown by calculation that the voltage effect on the Central Hudson system due to out-of-phase closing is no worse than what is allowable during motor starting, based on [Figure 9](#).

9. Specific Requirements for Inverter-Based DER

a. General Inverter

As described in [Section IV. A. 2. b. “Type Tested and Certified Inverters.”](#) it is recommended to utilize inverters that are certified and tested in accordance with the most recent revision of UL 1741 and its Supplement A. These systems will be subjected to the requirements within the most current version of IEEE 1547 as well as the requirements listed in [Section IV. A. 2. a. “Fail Safe and Redundancy.”](#) Settings approved by Central Hudson will be verified in the field during field verification.

Line-commutated inverters do not require synchronizing equipment. Self-commutated inverters, however, do require synchronizing equipment unless it can be shown by calculation, and confirmed at the time of verification testing, that the effect on the Central Hudson system from out-of-phase closing is no worse than what is allowable during motor starting. Direct current generation only can be installed in parallel with Central Hudson’s system using a synchronous inverter. The design shall be such as to disconnect this synchronous inverter upon a Central Hudson system event. Synchronization or re-synchronization of an inverter to Central Hudson shall not result in a voltage and frequency deviation that exceeds the requirements contained within [Section IV. A. 6. “Power Quality.”](#) Inverters intended to provide local grid support during system events that result in voltage and/or frequency excursions as described in [Section IV. A. 9. d. “Future Considerations for Smart Inverters”](#) shall be provided with the required onboard functionality to allow for the equipment to remain online for the duration of the event.

The minimum protective requirements for inverters are listed below. The need for additional protective functions shall be determined by Central Hudson on a case-by-case basis. If Central Hudson determines that additional functions are required, the Interconnection Customer will be notified of such.

The following are the minimum protective functions for Inverter-Based DER:

- Over/Under Voltage
 - Function 59
 - Function 27
- Over/Under Frequency
 - Function 81O
 - Function 81U
- Anti-Islanding Protection

b. [Requirements for PV systems](#)

The Interconnection Customer is required to inform Central Hudson of any settings outside of the default IEEE 1547 requirements or default manufacturer settings, including power factor. Unless specified otherwise, inverters are required to operate at unity power factor. Depending on system conditions and interconnection feasibility, Central Hudson may grant the Interconnection Customer permission to operate the inverters at an alternative fixed power factor to mitigate system interconnection issues such as high voltage. The appropriate power factor set points (either leading or lagging) will be determined by Central Hudson based on system conditions. Power factor adjustments shall be completed by the inverter manufacturer and shall not be altered by any other party. At no point should the Interconnection Customer have access to alter the inverter's power factor or other factory settings. If Central Hudson determines the inverters are operating at a different power factor than what was agreed to as a result of the Impact Study, Central Hudson reserves the right to disconnect and lock off the DER System. Refer to [Section IV. A. 9. d. "Future Considerations for Smart Inverters."](#) Note that when adjusting inverter power factor on a static basis, an additional switched capacitor bank that is sized based on the amount of VARs being consumed by the DER System may need to be installed to improve system power factor and reduce losses that occur as a result from absorbing VARs on the Central Hudson system.

In addition to power factor adjustment settings, in some cases Central Hudson may allow the inverter's maximum output to be curtailed in order to help reduce overall interconnection costs.

c. Requirements for Energy Storage Systems

It is recommended that ESS utilize inverters and converters that are UL-1741-SA certified. ESS applications that incorporate the use of control relays in order to meet IEEE 1547 Standards and/or limit the import or export capabilities shall utilize Utility Grade Devices. A customer-owned Utility Grade backup relay also may be required.

The configuration and characteristics of the energy storage system such as a standalone ESS vs. Hybrid, AC vs. DC coupled, or systems incorporating charging/discharging limitations may require additional Central Hudson metering as well as reverse power relay requirements. ESS applications should include all details associated with the operation of the ESS, as well as associated equipment. Central Hudson will analyze ESS proposals during Impact Studies under worst case scenarios if operating characteristics or control schemes do not indicate otherwise. Once operating characteristics for ESS are reviewed and approved by Central Hudson, these settings are not permitted to be adjusted or altered. Changes to settings will require resubmission and review by Central Hudson. For ESS that fall within the jurisdiction of the NYSSIR, refer to the latest revision of the NYSSIR for a detailed list of application requirements as well as timelines associated with ESS.

d. Future Considerations for Smart Inverters

Smart inverters are inverters equipped with advanced functionality that can provide support to the grid. This includes but is not limited to the following capabilities:

- Real power output curtailment
- Active regulation of voltage by changing real and reactive power
- Providing modulated power output as a function of frequency
- Adjustment of clearing times in response to abnormal voltage and frequency
- Low/high voltage and frequency ride through
- Ramp rate adjustment
- Power factor adjustment
- Soft start reconnection capabilities

Unless otherwise specified, Central Hudson requires that any smart enabled inverters utilize default IEEE 1547-2018 settings. Depending on grid characteristics and operating conditions, Central Hudson may request certain advanced functions to be enabled. This includes adjusting inverter set points to meet the NPCC curve for underfrequency trip settings (see Standard PRC-006-NPCC-1 or later, *Automatic Underfrequency Load Shedding*, Figure 1) in order to comply with Central Hudson's

underfrequency load shedding program. Volt-VAr capabilities or power curtailment also may be beneficial to the Interconnection Customer for lower cost integration.

10. AC Visible Disconnect Switch Requirements

All generating equipment, with the exception of inverter-based generation with nameplate ratings below 25kW, shall be equipped with an electrical load break disconnect switch accessible to Central Hudson at all times. The AC disconnect switch shall be capable of isolating the DER System from the Central Hudson system by means of an external, manual, visible break, gang-operated, load break disconnecting switch. The disconnect switch shall be installed, owned, and maintained by the Interconnection Customer, and located within 10 feet of the Central Hudson meter. The disconnect switch shall be clearly marked, "Generator AC Disconnect Switch," with permanent placard 3/8 inch or larger letters.

The disconnect switch shall be readily accessible for operation and be capable of being locked in the open position by a Central Hudson owned standard padlock. The disconnect switch shall be rated for the voltage and current requirements of the installation. Disconnect devices shall also meet all applicable requirements of the most current revision of UL, ANSI, and IEEE standards, and shall be installed to meet all applicable local, state, and federal codes.

In the event the disconnect switch cannot be installed within 10 feet of the Central Hudson meter, the Interconnection Customer shall propose an alternate disconnect location and provide it to Central Hudson for review and approval. Note that additional permanent placards, including a map to the location of the AC disconnect, also will be required.

For DER Systems that are an expansion to an existing system, separate AC disconnect switches for each system will not be acceptable. A single AC disconnect shall be installed to disconnect ALL generating equipment behind the Interconnection Customer's meter. For systems that are primary metered and utilize multiple system step-up transformers, AC disconnects may be required to be on the primary side in order to meet requirements listed above.

11. Monitoring & Control

a. Summary of Requirements

Central Hudson's monitoring and control requirements are determined by the aggregate AC nameplate rating of the DER System, the specific electrical system characteristics at the POI and the aggregate quantity of additional DER in proximity to the system under review. The Central Hudson monitoring and control requirements as outlined below apply to all customer-owned DER Systems with an aggregate AC nameplate rating of 500 kW or greater. These requirements may also apply to sites with aggregate AC nameplate rating of 50kW-500kW based on review by Central Hudson.

[Figure 10](#) shows an example of a DER System that meets Central Hudson’s monitoring and control requirements for inverter-based DER sites without a PCC recloser.

Central Hudson will select the equipment and provide acceptable communications mediums to be used. All equipment costs are the responsibility of the Interconnection Customer as is the cost of the communication medium from the Interconnection Customer’s site to Central Hudson’s Control Center. The customer shall also cover the reoccurring communication costs associated with monitoring and control.

If the installation of an electronic recloser is required at the Interconnection Customer’s PCC, it also may be used as a part of the monitoring and control package. Central Hudson will procure and install this device at the Interconnection Customer’s cost.

b. Monitoring Requirements

Monitoring a DER site requires the communication of real-time telemetering and device status information from the site to Central Hudson’s Control Center. All monitored data shall be remotely accessible through DNP3 protocol by Central Hudson’s SCADA systems. All analog quantities shall be metered at the PCC.

The minimum required data values are as follows:

- Per phase voltage and current
- Three phase real and reactive power
- Power factor
- MWHrs at the end of each hour
- PCC device status

Additional monitoring points may be required based on review by Central Hudson. Additional monitoring and control also may be required if the Interconnection Customer chooses to participate in NYISO markets.

c. Control Requirements

Control of a DER site refers to Central Hudson’s ability to remotely change the status of an interrupting device. At a minimum, Central Hudson shall be able to remotely trip and close the main circuit breaker or recloser located at the DER site’s PCC, but additional requirements may be necessary. Control shall be provided using DNP3 protocol.

B. Utility System Modifications and Upgrades

The interconnection of DER facilities alters the transient and steady-state powerflow levels in the Central Hudson system. These variations can adversely affect grid safety, reliability,

and efficiency. Utility system modifications may be required to mitigate the negative effects of an interconnected DER System. Central Hudson will determine these requirements during the review process. The Interconnection Customer is responsible for the cost of all utility system reinforcements necessary to connect their DER System to the Central Hudson grid.

1. Constraints Requiring Utility Modifications and Upgrades

DER interconnections have the potential to cause adverse impacts to the Central Hudson system. The potential constraints requiring utility reinforcement depend on the proposed DER System AC nameplate rating as well as characteristics of the feeder at the Point Of Interconnection. The following categories list the potential impacts associated with interconnections.

a. Thermal Overload

DER Systems interconnecting to the grid have the potential to exceed power system ratings, resulting in thermal overloads. The Central Hudson system has various equipment components, each with its own thermal rating as well as capability to detect reverse power flow. Once an Interconnection Customer applies for interconnection, thermal ratings of all the components on a feeder that are in-line with the DER System need to be considered. If it is found that any device will be thermally overloaded, then that device will need to be upgraded at the Interconnection Customer's expense. To provide margin for smaller residential systems seeking interconnection, as well as reduce the potential for additional power quality impacts, Central Hudson's practice is to upgrade equipment when the proposed system causes the equipment to reach 85-90% of the thermal rating of equipment.

b. Reverse Power Flow

Reverse power flow through distribution, substation, or transmission equipment will occur whenever the generation from the DER System exceeds the load conditions at that time. If it is found that the new DER System will cause reverse power flow, all equipment will be verified to ensure it can support it. If any equipment upgrades are needed to support reverse power flow, these will be done at the Interconnection Customer's expense.

c. Operational Contingencies

During impact studies, DER Systems are studied as part of the normal configuration of a distribution feeder. As a result, if the feeder enters an alternate configuration, the DER System is not permitted to operate during this time. Feeder reconfiguration may occur due to operational changes such as outages, switching, maintenance, testing, or automatic load transfers. These scenarios may require Central Hudson to disconnect the DER System during planned or unplanned events. As described in [Section IV. A. 10. "AC Visible Disconnect Switch Requirements,"](#) the Interconnection Customer shall install an electrical load break disconnect switch accessible to Central

Hudson at all times. Unless the DER System was requested to be studied and approved for operation in an alternate configuration per the NYSSIR Standardized Contract requirements (Appendix A), Central Hudson will utilize the disconnect switch as the means to disconnect the DER System when required. In some cases where automated load transfers may occur, a PCC electronic recloser may be required at the Interconnection Customer's cost in order to trip the DER System offline once the automatic transfer scheme operates.

Additionally, system voltage and/or thermal constraints exist when the Central Hudson transmission system is placed in certain alternate configurations. The Impact Study will determine whether or not a DER System may operate in parallel with Central Hudson during these alternate transmission configurations. If the DER System is not permitted to operate in these configurations, a DTT scheme will be required (at the Interconnection Customer's cost) to disconnect the DER System during an identified transmission contingency.

In cases where it is known that an outage may occur and remove or add a significant portion of load downstream from the DER site, Central Hudson will use engineering judgment on whether or not to consider this scenario as part of Impact Study results. This includes reviewing if the generation can match or exceed the load during this N-1 scenario that may cause reverse power flow, load rejection overvoltage, or additional power quality concerns. Additionally for ESS, Central Hudson may need to review whether the addition of the ESS load will cause any thermal or power quality violations. Central Hudson will review these scenarios and determine if any additional upgrades are required. The upgrades associated with DER Systems are described further in [Section IV. B. 2. "Potential System Upgrades."](#)

d. Distribution Automation

As part of Central Hudson's Distribution Automation initiative, Central Hudson implements ALT schemes so that the fewest number of customers experience permanent interruptions due to an outage in an area. For DER and ESS already requiring a PCC recloser located in an area that utilizes an ALT scheme, the PCC electronic recloser may be required to trip offline when Central Hudson's system is operating in an alternate configuration.

While Central Hudson's ALT schemes currently operate decentralized, Central Hudson is in the process of implementing a centralized Distribution Management System (DMS). The new technologies which will be installed as part of the DMS will enable more robust system models that incorporate the impact of DERs. This includes allowing the DMS to perform load flow calculations to enable DER Systems to potentially remain online during alternative configurations, in lieu of tripping the system off. In the near term, Central Hudson's Smart Grid Strategy aims to accommodate DERs through greater monitoring and, in some cases, control. Over the longer term, Central Hudson may seek

to remotely operate DERs in real time for purposes of preserving system safety and reliability.

e. Voltage Regulation

As part of an Impact Study, Central Hudson analyzes DER impacts to existing voltage regulation equipment. This includes any distribution line regulators, substation feeder head regulators, and substation transformer LTCs. With the DER System generating or charging at its full nameplate rating, the DER System is not permitted to cause excessive tap movement on voltage regulating equipment upon going offline or switching from charging to discharging mode, and vice-versa. In addition, the interconnection of the DER System shall not result in a voltage change greater than half the bandwidth of any feeder voltage regulating device. Excessive tap movement not only impacts existing voltage regulation capabilities but also causes wear and tear on regulators which can lead to an increase in device maintenance as well as an overall shorter lifespan.

f. Power Quality

In order to maintain adequate voltage for all customers, Central Hudson shall regulate voltage within ANSI C84.1 limits. As such, Central Hudson will verify that the DER System will not cause the grid to exceed the ANSI voltage limits outside of 114V to 126V.

The DER System shall also not cause excessive rapid voltage changes or flicker. Voltage flicker limits are defined by IEEE 1453. Rapid voltage change thresholds are defined per IEEE 1547 and require limiting the voltage change to not exceed 3% of nominal voltage at the PCC and 5% of nominal voltage at the substation based on aggregate DER on the feeder.

g. Protection

(1) Anti-Islanding Protection

An electrical island is formed when a DER System becomes isolated with and continues to feed a portion of customer load. Islands can result in poor customer power quality. Furthermore, islanding can cause equipment damage when automatic reclosing devices attempt to reconnect an unsynchronized island to the Central Hudson source. Central Hudson implements autoreclosing on many of its distribution protective devices to allow automatic restoration of customers following a transient fault on a circuit. It is imperative that all generation is disconnected from the system before Central Hudson's protective equipment recloses.

No DER System shall be allowed to island with any part of the Central Hudson system unless it is a part of an approved microgrid. When reviewing an

Interconnection Customer's application, Central Hudson will perform a study to determine the DER System's risk of islanding. If it is determined that there exists a possibility of islanding, the Interconnection Customer shall be responsible for utility reinforcements to mitigate this risk. These may include, but are not limited to:

- The installation of a DTT scheme to directly trip the DER System via a communications signal.
- The installation of a Reclose Block (dead line sensing) scheme to block circuit breaker automatic reclosing until the circuit is deenergized.

The more cost effective option will be applied wherever possible.

(2) Substation Overvoltage Protection

If a DER System is installed on a circuit connected to substation transformers which are delta connected on the high voltage side, fault current contribution from the DER System during a high side ground fault can cause overvoltages of up to 1.73 per unit of phase to ground voltage on the high side of the transformer. These high voltages can damage Central Hudson and customer equipment. Overvoltage conditions cannot typically be detected by existing protection. In these cases, the Interconnection Customer will be required to pay for all substation upgrades necessary to detect and mitigate an overvoltage condition.

2. Potential System Upgrades

In order to mitigate the potential impacts as described in [Section IV. B. 1. "Constraints Requiring Utility Modifications and Upgrades,"](#) utility upgrades may be required in order to reduce impacts to the grid. The level of utility upgrades required depends on several factors such as DER System AC nameplate rating, technology, location, operating characteristics and existing infrastructure. The upgrades required and associated estimated costs are provided after Impact Study results such as a CESIR, or after technical screening if a CESIR is not required. The following lists the most common utility system upgrades that DER Systems may be required to pay for prior to interconnection or commencing any construction work, as a result of their system's impact to the electrical grid. It is Central Hudson's policy to prioritize the most cost effective upgrade solutions first in order to reduce the level of interconnection costs to the Interconnection Customer.

a. Distribution

The following are examples of distribution upgrades that may be required to mitigate the effects of a DER System. This list is not comprehensive and Central Hudson may

require upgrades other than those listed here. All equipment design, procurement, engineering, and construction will be performed by Central Hudson at the Interconnection Customer's expense, with the exception of the upgrades marked "customer responsibility" below. Additional exceptions also may exist for projects that fall under NYISO jurisdiction.

- Mitigate Voltage Level or Voltage Regulation Concerns

If the Interconnection Customer's proposed DER System may cause high voltage levels or interfere with existing voltage regulation schemes, upgrades or changes to the distribution equipment may be required. Distribution system work may include, but is not limited to:

- Adjustment of customer transformer taps
- Replacement of existing Interconnection Customer transformer
- Installation of dedicated Interconnection Customer transformer
- Adjustment of inverter power factor (customer responsibility)
- Curtailment of overall inverter output (customer responsibility)
- Installation of switched capacitor banks
- Replacement of fixed capacitor bank with switched capacitor banks
- Replacement of voltage regulators
- Changing of existing voltage regulator controller settings
- Upgrading of primary conductor
- Upgrading of DER System conductor (customer responsibility)
- Conversion of single-phase/low voltage circuitry to three-phase 13.2 kV
- Phase balancing

- Eliminate Voltage Backfeed From Interconnection Customer Site (customer responsibility)

If the Interconnection Customer's proposed DER System may cause backfeed voltage during an open-phase condition on the Central Hudson system, an additional customer-owned protective device may be required. Distribution system work may include, but is not limited to:

- Installation of an additional interrupting device (for example, an electronic recloser) at the Interconnection Customer's site

- Installation of additional protective relaying at the Interconnection Customer's site
- Mitigate Voltage Flicker Conditions

If the Interconnection Customer's proposed DER System may cause voltage flicker outside of the allowable range of IEEE 1453, upgrades or changes to the distribution equipment may be required. Distribution system work may include, but is not limited to:

- Adjustment of inverter power factor (customer responsibility)
- Curtailment of overall inverter output (customer responsibility)
- Upgrading of primary conductor
- Upgrading of DER System conductor (customer responsibility)
- Conversion of single-phase/low voltage circuitry to three-phase 13.2 kV

- Mitigate Thermal Limit Concerns

If the Interconnection Customer's proposed DER System will contribute enough current to exceed the thermal limits of Central Hudson equipment, upgrades or changes to the distribution equipment may be required. Distribution system work may include, but is not limited to:

- Replacement of existing Interconnection Customer transformer (responsibility to be determined based on Impact Study)
- Installation of dedicated Interconnection Customer transformer (responsibility to be determined based on Impact Study)
- Adjustment of inverter power factor (customer responsibility)
- Curtailment of overall inverter output (customer responsibility)
- Replacement or reprogramming of existing protective or sectionalizing devices
- Upgrading of primary conductor
- Upgrading of DER System conductor (customer responsibility)
- Conversion of single-phase/low voltage circuitry to three-phase 13.2 kV

- Maintain Distribution Protection Coordination and Relay Reach

If a protection study shows that the Interconnection Customer's proposed DER System will cause miscoordination between existing Central Hudson

overcurrent devices, or will cause the reach of those devices to be reduced, adjustments to protection settings or fuses may be required to restore coordination and reach. Distribution system work may include, but is not limited to:

- Replacement or reprogramming of existing Central Hudson fuses or reclosers
 - Installation of an additional interrupting device (for example, an electronic recloser) at the Interconnection Customer's site (customer responsibility)
 - Installation of additional protective relaying at the Interconnection Customer's site (customer responsibility)
- Mitigate Unintentional Islanding Concerns

If an anti-islanding risk assessment study shows that there is a risk of an Interconnection Customer's inverter-based DER System islanding with other customer load, a DTT or reclose block scheme may be required on the distribution system. Distribution system work may include, but is not limited to:

- DTT
 - Installation of communications equipment at the substation and at the Interconnection Customer's site
 - Installation of a communications channel between the substation and the Interconnection Customer's site
 - Installation of an electronic recloser at the Interconnection Customer's site
 - Reclose Block
 - Replacement or reprogramming of existing upstream fuses or reclosers
 - Installation of an electronic recloser at the Interconnection Customer's site
- Mitigate Phase Imbalance

If the Interconnection Customer's proposed DER System will be connected as a single-phase system and will cause greater than 10% imbalance on the Central Hudson system, distribution system work to mitigate such imbalance may include, but is not limited to:

- Phase balancing

- Installation of additional primary conductors in single and two-phase locations (Polyphasing)
- Installation of three-phase DER System (customer responsibility)
- Install a Dedicated Feeder

When the mitigations listed above cannot successfully mitigate all negative impacts observed during a study, a dedicated feeder may be required to be constructed and built to the DER site. This allows the DER System to still interconnect while not causing adverse impacts to other Central Hudson customers sharing the same line.

Central Hudson typically will construct a dedicated feeder along an existing pole plant and thus “double circuit” the line. However, depending on field conditions, existing easements and right-of-ways, alternate routes or underground installation may be required.

b. Substation

The following are examples of substation upgrades that may be required for interconnection of a DER System. This list is not comprehensive and Central Hudson may require upgrades other than those listed here. All equipment selection, engineering, and construction within the substation will be completed by Central Hudson at the Interconnection Customer’s expense. Additional exceptions may also exist for projects that fall under NYISO jurisdiction.

- Implement Reclose Block Scheme on Substation Circuit Breaker

If an anti-islanding risk assessment study shows that there is a risk of an Interconnection Customer’s inverter-based DER System islanding with other customer load, a reclose block scheme may be required at the substation circuit breaker. Substation work may include, but is not limited to:

- Changes to existing relay settings
- Replacement of existing relays
- Installation of potential transformers or other voltage sensing devices

- Implement DTT Scheme Between Substation and Interconnection Customer DER System

If an anti-islanding risk assessment study shows that there is a risk of an Interconnection Customer’s non-inverter-based DER System islanding with other customer load, or if Central Hudson system conditions require direct tripping of the Interconnection Customer’s DER System, a DTT scheme may be required. Substation work may include, but is not limited to:

- Installation of communications equipment at the substation and at the Interconnection Customer's site
- Installation of a communication medium between the substation and the Interconnection Customer's site
- Changes to existing relay settings
- Install Overvoltage Protection at Substation

If an Interconnection Customer's DER System will cause substation overvoltages during ground faults, a 3V0 overvoltage detection scheme may be required at the substation to detect and mitigate ground faults. Substation work may include, but is not limited to:

- Installation of primary and backup 3V0 voltage sensing relays
- Installation of potential transformers or other voltage sensing devices
- Replacement of existing equipment (e.g. arresters, bus, insulators) with higher-rated equipment

- Modify Substation Relay Overcurrent Settings or Fuses

If a DER System's fault current contribution will cause reduction of relay reach or coordination issues between existing Central Hudson protective devices, adjustments to relay settings or fuses may be required to restore coordination and relay reach. Substation work may include, but is not limited to:

- Changes to existing relay settings or fuses
- Replacement of existing relays or fuses

- Modify Substation LTC

If an Interconnection Customer's DER System will backfeed power to the substation bus or transformer, adjustments to substation LTC controllers or settings may be required to account for bidirectional power flow at the bus or transformer. Substation work may include, but is not limited to:

- Changes to existing LTC settings
- Replacement of existing LTC controls

- Install a Dedicated Distribution Circuit to Interconnection Customer's Site

If Central Hudson's study determines that the DER System's capacity cannot be accommodated on an existing circuit, a dedicated distribution circuit may be required to interconnect the DER System to the Central Hudson system. Substation work may include, but is not limited to:

- Installation of a new circuit breaker, instrument transformers, and protective relays
- Installation of a new circuit riser cable
- Changes to existing relay settings or fuses
- Replacement of existing relays or fuses
- Extension or replacement of existing equipment (e.g. arresters, bus) with higher-rated equipment
- Replace Existing Substation Transformer or Install an Additional Substation Transformer

If a DER System’s power output, or peak charging in conjunction with existing load, will exceed a specified percentage of the rating of the existing substation transformer, an additional substation transformer or replacement of the existing transformer may be required to accommodate the increased power flow. Substation work may include, but is not limited to:

- Replacement of the substation transformer
- Installation of an additional substation transformer
- Changes to existing relay settings or fuses
- Replacement of existing relays, controllers, or fuses
- Replacement of existing equipment (e.g. arresters, bus) with higher-rated equipment

c. Transmission

The following are examples of transmission system upgrades that may be required to mitigate the effects of a DER System. This list is not comprehensive and Central Hudson may require upgrades other than those listed here. All equipment selection, engineering, and construction from the PCC up to and including the Central Hudson system will be done by Central Hudson at the Interconnection Customer’s expense. Additional exceptions may also exist for projects that fall under NYISO jurisdiction.

- Connect the Interconnection Customer’s DER System to a Central Hudson Transmission Line

If the Interconnection Customer’s DER System cannot be accommodated on the distribution system due to thermal or equipment constraints, the Interconnection Customer may be required to connect their system to a Central Hudson transmission line. Additional requirements for customers connecting to the transmission system are listed in [Section III. C. “NYISO](#)

[Interconnection Process.](#)” Transmission work may include, but is not limited to:

- Installation of transmission line tap to the DER System’s PCC
 - Installation of additional interconnection equipment (e.g. circuit breakers, transformers, arresters, bus, instrument transformers)
 - Installation of additional relaying or communication equipment at DER site
 - Modification of existing transmission line relay settings
 - Replacement of existing transmission line relays
 - Installation of a new substation and associated equipment
- Upgrade Transmission Line Conductor and Associated Equipment

If the proposed DER System has the potential to result in violation of transmission line thermal or equipment limits, upgrades to the transmission conductor and associated equipment may be required. Transmission work may include, but is not limited to:

- Replacement of all or part of the transmission line conductor and structures
- Replacement of existing equipment (e.g. arresters) with higher-rated equipment

C. System Testing and Operating Requirements

The Interconnection Customer’s DER System shall be thoroughly tested to ensure correct operation under all planned and unplanned grid conditions. Following system construction, the Interconnection Customer shall perform preliminary testing to verify equipment functionality and correct wiring. Prior to granting final approval for interconnection, the Interconnection Customer shall successfully complete a verification test. Once connected, the Interconnection Customer is required to perform additional testing if a system failure is discovered and whenever design modifications are made, as well as at least every four years to verify correct operation.

1. Preliminary Testing

Prior to the final verification testing, the Interconnection Customer should perform, as a minimum, the following testing at their site:

- (a) Test that all interconnection protection and control devices and functions operate at set points and operating characteristics as previously approved by Central Hudson.
- (b) Test settings of all interconnection protective devices and functions.

- (c) Ratio test all instrument transformers.
- (d) Polarity check all instrument transformers.
- (e) Saturation check of all current transformers (CTs).
- (f) Wire check all AC circuits.
- (g) Insulation resistance test (also commonly known as a Megger test) to test instrument transformers to verify insulation and secondary circuit integrity.
- (h) Functionally check all DC control circuits from point-to-point associated with the interconnecting system's protective devices and functions.

In order to facilitate preliminary testing, the Interconnection Customer should contact the Central Hudson Project Manager to request temporary energization if applicable, per the time limitations specified in the NYSSIR.

For inverter-based DER and ESS, the inverter shall utilize factory default settings unless otherwise approved by Central Hudson.

The Interconnection Customer shall submit signed documentation indicating that relay settings have been satisfactorily tested to the latest version of the settings approved by Central Hudson.

In addition, the Interconnection Customer should pre-test the verification test procedure prior to the final verification test. This includes testing that an inverter-based DER System meets UL 1741 standards by disconnecting single and three phases via a customer-owned load break disconnect switch.

2. Verification Testing

a. Minimum Requirements for Verification Testing

Verification testing validates the connection of the system and demonstrates that the protection and control schemes operate as designed under a variety of grid conditions. It also serves as a template for future periodic testing so that future test results can be compared to the initial results. It is the Interconnection Customer's responsibility to develop the verification test procedure and to arrange for the test to be performed. Central Hudson will approve the procedure and reserves the right to witness the test.

The verification test procedure shall, at a minimum, verify that:

- (a) All interrupting devices operate for all trip initiating conditions.
- (b) All interconnection protective relays and devices respond correctly, per their settings, to input conditions.

- (c) The interconnection protective system will be able to detect and isolate the Interconnection Customer's DER System for an open phase condition on the Central Hudson system.
- (d) The interconnection protective system will be able to detect and isolate the Interconnection Customer's DER System for a three phase loss of AC power on the Central Hudson system.
- (e) The Interconnection Customer's ground source will disconnect from the Central Hudson system when the DER System is not generating (if applicable).
- (f) The Interconnection Customer's DER System will respond correctly to all abnormal conditions if any single device experiences a failure or loss of control power.
- (g) Following a grid failure, the Interconnection Customer's DER System does not generate into the Central Hudson grid for a minimum of five minutes after AC power has been restored and voltage and frequency have returned to normal.

Wires may not be lifted during the verification testing, as this invalidates the test results.

At the conclusion of the verification test, immediately following the energization of the interconnection, AC voltages, currents, and phase angles should be measured in all protective devices to verify proper connections. These values shall be recorded and maintained with the project documentation.

[Figure 6](#) illustrates an example of a verification test procedure for a non-inverter based system. [Figure 7](#) illustrates an example of a verification test procedure for an inverter-based system.

b. Central Hudson Witnessing of Verification Testing

Central Hudson may witness the final verification test performed by the Interconnection Customer or his or her contractor. This test will not be scheduled until the following is completed:

- (a) The Interconnection Customer's full interconnection design package, including the protective device settings and verification test plan, has been approved by Central Hudson.
- (b) The Interconnection Customer has performed preliminary testing of their system and submitted the results to Central Hudson.
- (c) The Interconnection Customer's site has been inspected by an approved Electrical Inspector and proof of Electrical Inspection (such as a certificate)

has been submitted to Central Hudson. A list of approved Electrical Inspection agencies can be found on Central Hudson's website.

- (d) New service installations/upgrades as well as meter changes have been completed (if applicable).
- (e) Central Hudson system modifications have been completed (if applicable).

Once the above requirements have been met the Interconnection Customer shall contact Central Hudson to schedule a date and time for the verification test. Testing will be completed during Central Hudson's business hours, Monday-Friday 8am-4:30pm, excluding holidays.

If the DER System fails any portion of the verification test due to the system design, the Interconnection Customer is required to resubmit any design changes to Central Hudson. After Central Hudson reviews and approves changes to the system design and preliminary testing has been completed where applicable, a subsequent verification test can be scheduled.

3. Operations, Maintenance, and Future Testing

Central Hudson requires that all DER interconnections maintain proper Operation and Maintenance (O&M) procedures through the life of the system. DER Systems are required to perform maintenance and verification testing of their systems at least once every 4 years. This includes, but is not limited to the following:

- Verification that the system continues to meet all applicable UL 1741 and IEEE Standards concerning disconnection and reconnection times
- Battery maintenance testing
- Replacement of Interconnection Customer's protective devices as needed
- Periodic operation of switches to ensure functionality
- Firmware updates completed following manufacturer suggestion or requirements
- Verification that the system continues to conform with all other applicable safety and security standards

Central Hudson requires that the Interconnection Customer maintain an Operating Log that records all pertinent information concerning the operation of the DER System, including O&M. The log should include at a minimum:

- Dates and times the DER System goes online and offline
- Record of all relay, breaker, or inverter operations

- Record of all maintenance on protection equipment

This log, or a copy, shall be presented to Central Hudson upon request, with the results of the Interconnection Customer's scheduled maintenance. At all other times, this log shall be readily available to Central Hudson. Results of any maintenance testing or failures which require the replacement of equipment or changes in system design shall be reported to Central Hudson. Additionally, if modifications are made to the interconnection system design and/or protective scheme for any reason, the Interconnection Customer shall resubmit to Central Hudson, for review and acceptance, new specifications and updated one-line and three-line diagrams as well as a new verification test procedure. Following acceptance of the revised design and verification test, the portion of the test addressing the field modifications shall be conducted. Central Hudson reserves the right to inspect the Interconnection Customer's installation and request to witness a verification test at any time, upon reasonable notice to the Interconnection Customer. If the DER System is determined to cause adverse power quality or reliability issues, Central Hudson reserves the right to disconnect the DER System until mitigations, at the Interconnection Customer's cost, have been performed.

In addition to the requirements above, DER Systems are also required to meet the O&M requirements listed in Central Hudson's *Specification and Requirements for Electric Installations* as well as the latest NYSSIR (if applicable).

4. Utility Disconnection of Customer DER System

Central Hudson reserves the right to disconnect the DER System during emergency events without prior notice to the Interconnection Customer. For non-emergency events, Central Hudson will provide notice to the responsible party within a reasonable timeframe prior to disconnecting the DER System.

Central Hudson reserves the right to open and lockout the Interconnection Customer's generation for any of the following reasons:

- Emergency conditions on the Central Hudson system including by not limited to:
 - To eliminate conditions that constitute a potential hazard to utility personnel or the general public
 - If pre-emergency or emergency conditions exist on the utility system
 - If a hazardous condition relating to the DER System is observed by a utility inspection
 - If the Interconnection Customer has tampered with any protective, monitoring, or control device
- Non-emergency conditions on the Central Hudson system including by not limited to:

- The Interconnection Customer has failed to make available records of verification tests and proper maintenance of protective devices
- The Interconnection Customer has failed to provide final payment for items requiring reconciliation
- The Interconnection Customer's system interferes with Central Hudson's equipment or other Central Hudson's customers equipment
- The Interconnection Customer's system interferes with the power quality of service of nearby customers
- The DER System is not in compliance with operating parameters agreed upon during the interconnection process
- The need for routine maintenance, construction, or repairs on the Central Hudson system that may require alternate configurations
- When required protective relaying or special equipment that is necessary for operating control on Central Hudson's system is altered, inoperable or missing

V. Future Revisions

A. NYSSIR

Central Hudson follows the most recent revision of the NYSSIR for applications that fall under this jurisdiction. In addition, industry collaboration through the Interconnection Technical Working Group (ITWG) and Interconnection Policy Working Group (IPWG) may result in the development of supplemental documents, and updates to the NYSSIR may supersede requirements in this document prior to the opportunity to update it for consistency.

The most recent version of the NYSSIR as well as Statewide Interconnection Documents established from ITWG and IPWG meetings can be found on the Department of Public Service's Distributed Generation website.

B. NYISO Requirements

For projects that are applying through the NYISO Interconnection Process, as described in [Section III. C. "NYISO Interconnection Process."](#) the Interconnection Customer will be required to follow the NYISO's latest application process and requirements. The most recent versions of the applicable documents can be found on the NYISO's website.

C. Regulatory Orders

Various regulatory changes and new policy initiatives may be introduced that can affect the overall interconnection process and existing requirements. This includes the goals and initiatives associated with New York State's comprehensive energy strategy known as Reforming the Energy Vision (REV). Proceedings on REV or other regulatory matters may result in future PSC Orders that supersede the requirements and processes listed within this document.

D. Industry Standards

All interconnection protective equipment shall be designed and tested to appropriate industry standards and codes as indicated in [Section IV .A. 1. a "Standards, Codes, and Guidelines."](#) Occasionally, updates and revisions to industry standards will occur, which may alter the existing requirements listed within this document as well as company standards found in Central Hudson's *Specification and Requirements for Electric Installations*. Adoption of newly revised standards may not be immediately implemented and required until fully reviewed by Central Hudson. Adoption of guidelines, such as those developed by IEEE, is at the discretion of Central Hudson.

Figure 1- Example of a One-Line Diagram: Three Phase Induction Generator

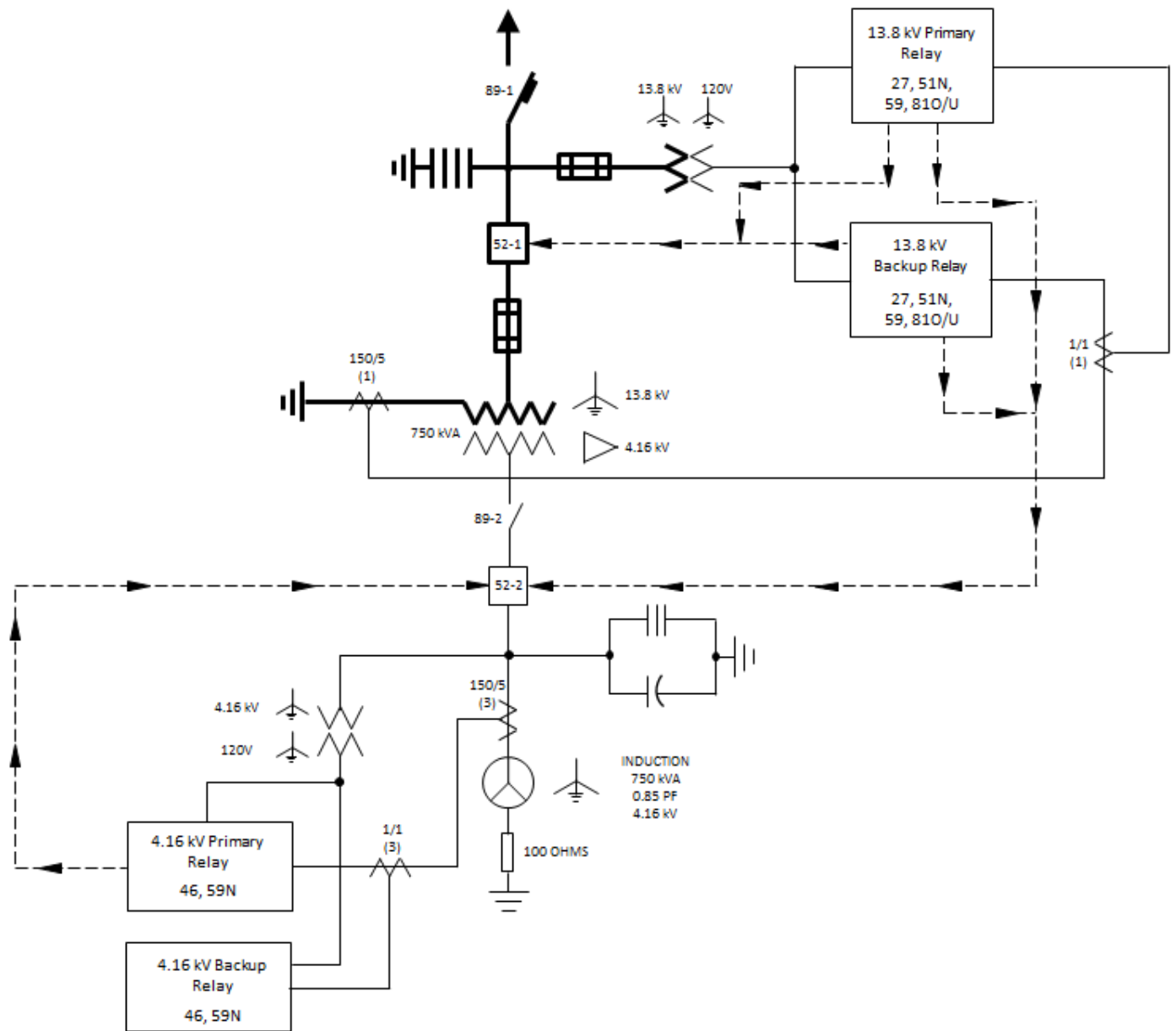

Notes:

1. Required monitoring/control not shown.
2. Protection for customer's system not shown.

Figure 1- Example of a One-Line Diagram: Three Phase Induction Generator (continued)

Central Hudson System Disturbances				
Abnormal Condition	Primary Protection		Back-Up Protection	
	Sensing Element	Disconnecting Device	Sensing Element	Disconnecting Device
Phase-Ground Fault	13.8 kV Primary Relay 51N	52-1 & 52-2	13.8 kV Backup Relay 51N	52-1 & 52-2
Two Phase-Ground Fault	13.8 kV Primary Relay 51N	52-1 & 52-2	13.8 kV Backup Relay 51N	52-1 & 52-2
Phase-Phase Fault	4.16 kV Primary Relay 46	52-2	4.16 kV Backup Relay 46	52-2
Three Phase Fault	13.8 kV Primary Relay 27	52-2	13.8 kV Backup Relay 27	52-2
Open Conductor	13.8 kV Primary Relay 51N	52-1 & 52-2	13.8 kV Backup Relay 51N	52-1 & 52-2

Isolation With Part of the Central Hudson System				
Abnormal Condition	Primary Protection		Back-Up Protection	
	Sensing Element	Disconnecting Device	Sensing Element	Disconnecting Device
Generation Less Than Load	13.8 kV Primary Relay 81U	52-1	13.8 kV Backup Relay 81U	52-1
Generation Greater Than Load	13.8 kV Primary Relay 81O	52-1	13.8 kV Backup Relay 81O	52-1

Figure 2- Example of a One-Line Diagram: Three Phase Synchronous Generator

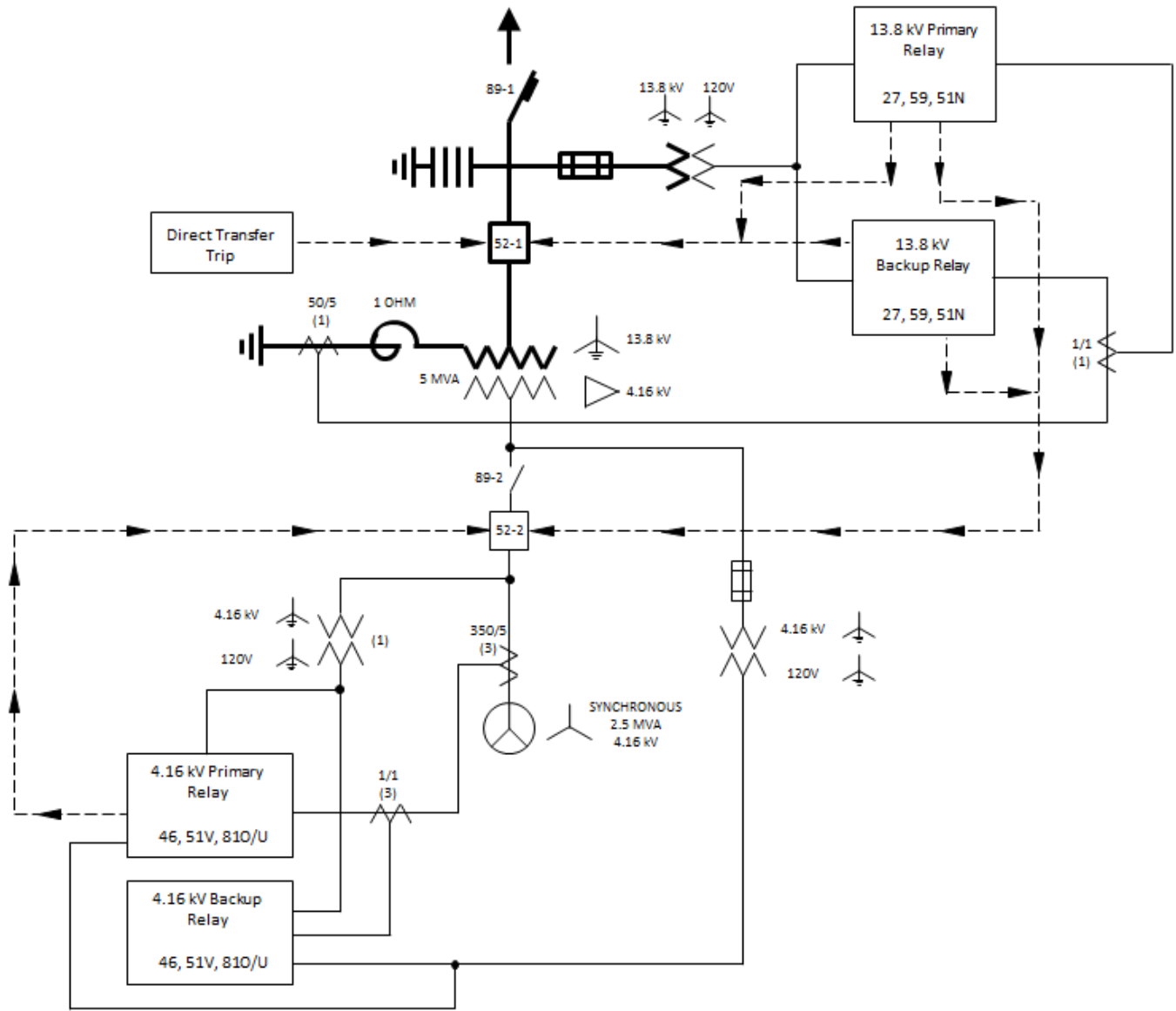

Notes:

1. Required monitoring/control not shown.
2. Protection for customer's system not shown.

Figure 2- Example of a One-Line Diagram: Three Phase Synchronous Generator (continued)

Central Hudson System Disturbances				
Abnormal Condition	Primary Protection		Back-Up Protection	
	Sensing Element	Disconnecting Device	Sensing Element	Disconnecting Device
Phase-Ground Fault	13.8 kV Primary Relay 51N	52-1 & 52-2	13.8 kV Backup Relay 51N	52-1 & 52-2
Two Phase-Ground Fault	13.8 kV Primary Relay 51N	52-1 & 52-2	13.8 kV Backup Relay 51N	52-1 & 52-2
Phase-Phase Fault	4.16 kV Primary Relay 46	52-2	4.16 kV Backup Relay 46	52-2
Three Phase Fault	4.16 kV Primary Relay 51V, 13.8 kV Primary Relay 27	52-2	4.16 kV Backup Relay 51V, 13.8 kV Backup Relay 27	52-2
Open Conductor	13.8 kV Primary Relay 51N	52-1 & 52-2	13.8 kV Backup Relay 51N	52-1 & 52-2

Isolation With Part of the Central Hudson System				
Abnormal Condition	Primary Protection		Back-Up Protection	
	Sensing Element	Disconnecting Device	Sensing Element	Disconnecting Device
Generation Less Than Load	4.16 kV Primary Relay 81U, 13.8 kV Primary Relay 27	52-2	4.16 kV Backup Relay 81U, 13.8 kV Backup Relay 27	52-2
Generation Greater Than Load	4.16 kV Primary Relay 81O, 13.8 kV Primary Relay 59	52-2	4.16 kV Backup Relay 81O, 13.8 kV Backup Relay 59	52-2

Figure 3- Example of a One-Line Diagram: Three Phase Inverter-Based DER System

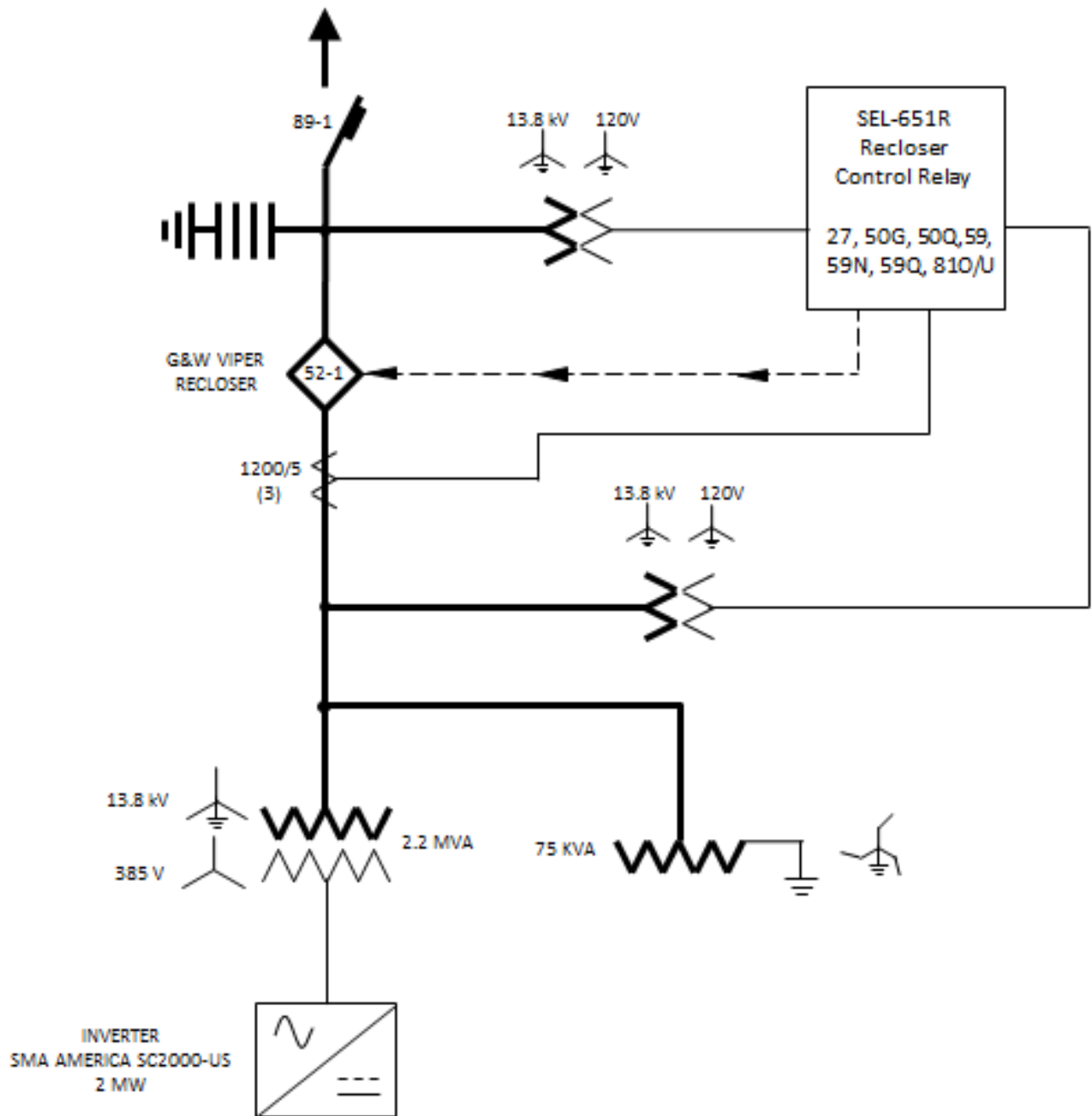

Notes:

1. All equipment shown is customer-owned.
2. Required monitoring/control not shown.
3. Additional protection for customer's system may be required.
4. Table 3 not required since both inverter and VIPER recloser are considered "Fail Safe" devices.

Figure 4- Example of a Three Line Diagram

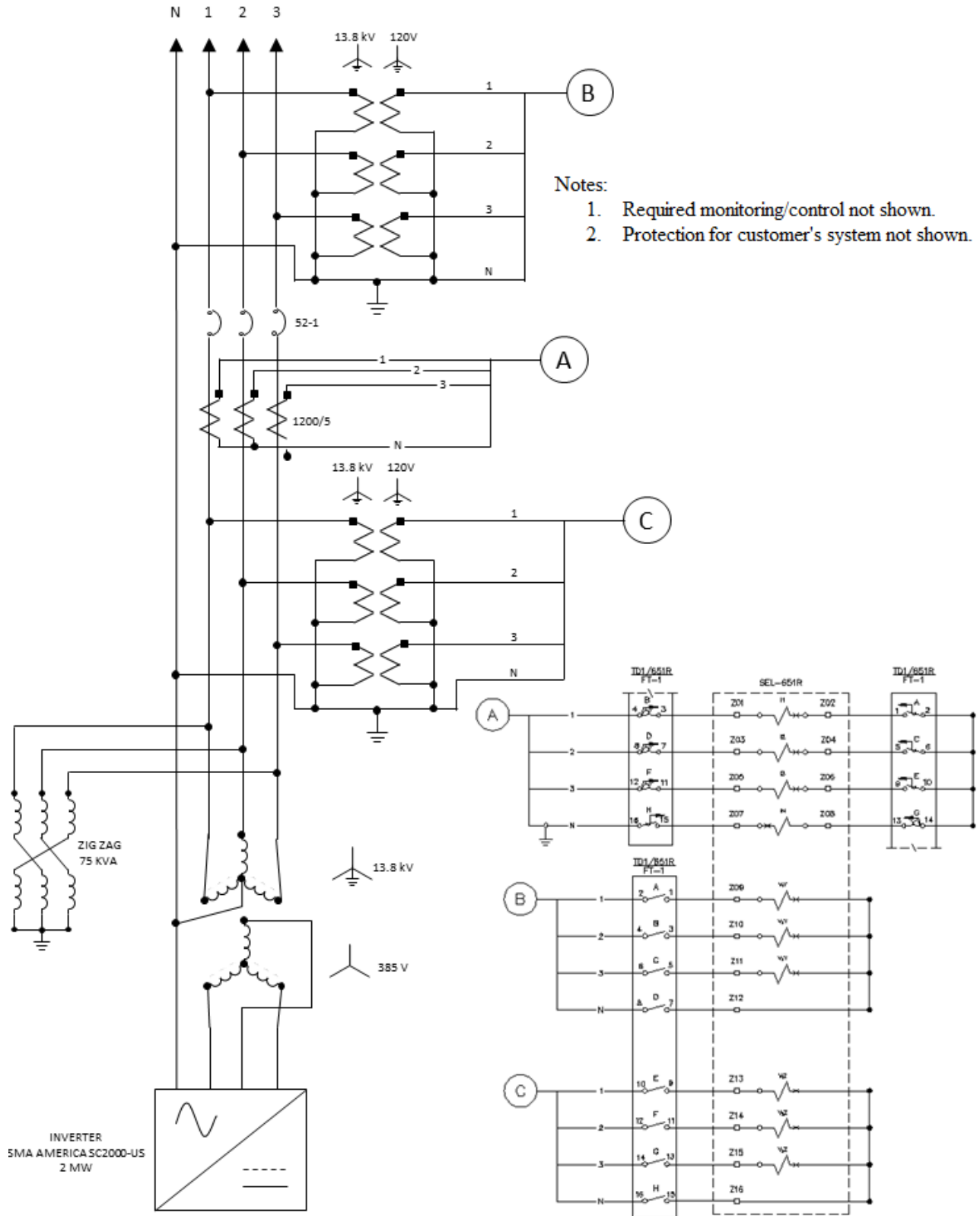

Figure 5- Example of a DC Control Schematic

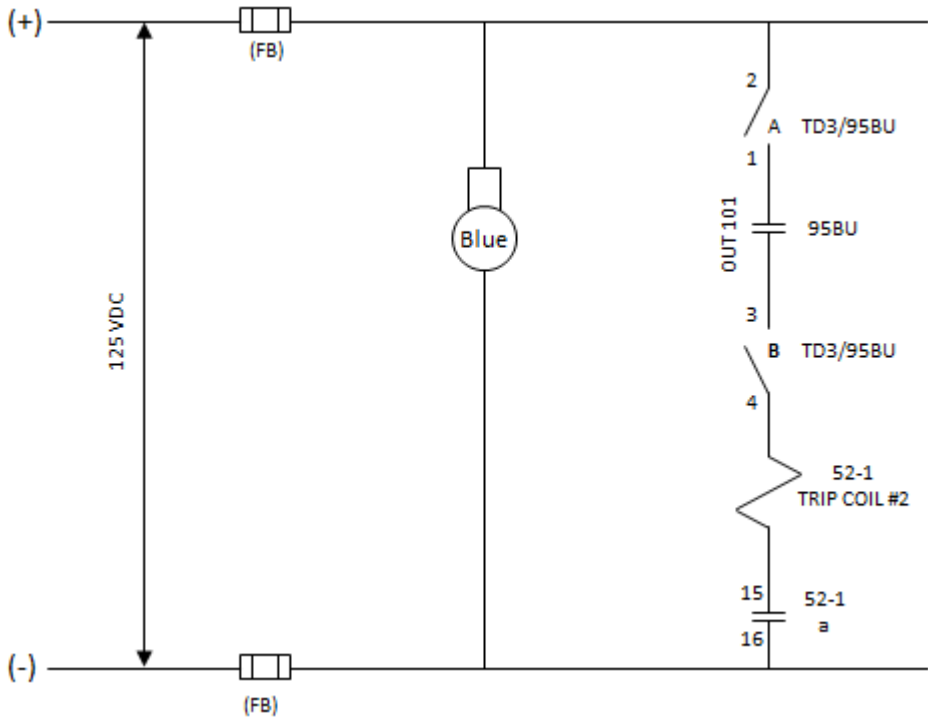
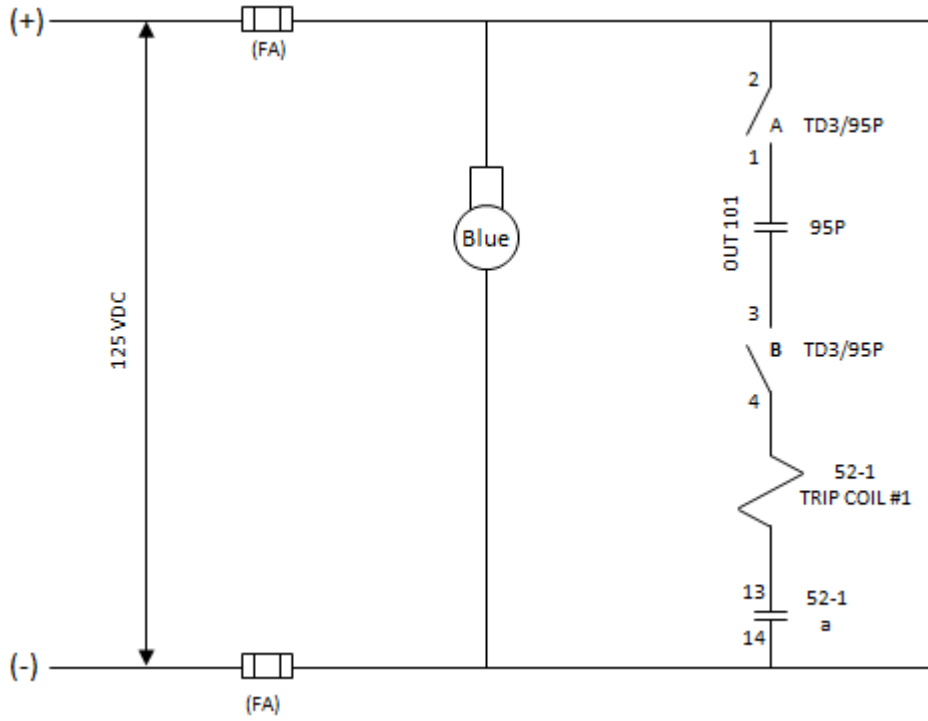

Figure 6- Example of a Functional Test Procedure for the Figure 2 One-Line Diagram

Note: Prior to the functional test being performed, preliminary testing will have been completed on all protective relays and other equipment. Additional functional testing of Central Hudson owned equipment may be required.

I. Protective Relay Settings.

Notes:

All settings will have been uploaded onto the protective relays prior to the functional tests. Factory test reports for all devices shall be submitted to Central Hudson prior to the functional tests.

Element	Setting
27-1 Pickup	105.6 V secondary
27-1 Time Delay	2 seconds
27-2 Pickup	54V secondary
27-2 Time Delay	0.16 seconds
59-1 Pickup	132 V secondary
59-1 Time Delay	1 second
59-2 Pickup	144 V secondary
59-2 Time Delay	0.16 seconds
51N Pickup	5.0 A secondary
51N Curve	U4
51N Time Dial	1.5
81U-1 Pickup	59.0 Hz
81U-1 Time Delay	300 seconds
81U-2 Pickup	57.0 Hz
81U-2 Time Delay	0.16 seconds
81O-1 Pickup	61.0 Hz
81O-1 Time Delay	180 seconds
81O-2 Pickup	61.8 Hz
81O-2 Time Delay	0.16 seconds
51V Pickup	10 A secondary
51V Curve	U4
51V Time Dial	1.2
46 Pickup	5% I ₂

II. Initial Setup

1. Open Breaker 52-1.
2. Open Breaker 52-2.
3. Open Switch 89-1.

4. Open Switch 89-2.

III. Test Tripping- 13.8 kV Primary Relay 27 Elements

Purpose: To verify the operation of the 27 undervoltage tripping elements in the 13.8 kV Primary Relay.

1. Connect a variable voltage source to the voltage terminals of the 13.8 kV Primary Relay.
2. Set the variable voltage source to 120 VAC.
3. Close Breaker 52-1.
4. Lower the Phase A voltage to just below 105.6 VAC.
5. Verify that Breaker 52-1 trips.
6. Return the variable voltage source to 120 VAC.
7. Close Breaker 52-1.
8. Lower the Phase B voltage to just below 105.6 VAC.
9. Verify that Breaker 52-1 trips.
10. Return the variable voltage source to 120 VAC.
11. Close Breaker 52-1.
12. Lower the Phase C voltage to just below 105.6 VAC.
13. Verify that Breaker 52-1 trips.
14. Return the variable voltage source to 120 VAC.
15. Close Breaker 52-1.
16. Disable the 27-1 element in the 13.8 kV Primary Relay.
17. Lower the Phase A voltage to just below 54 VAC.
18. Verify that Breaker 52-1 trips.
19. Return the variable voltage source to 120 VAC.
20. Close Breaker 52-1.
21. Lower the Phase B voltage to just below 54 VAC.
22. Verify that Breaker 52-1 trips.
23. Return the variable voltage source to 120 VAC.
24. Close Breaker 52-1.
25. Lower the Phase C voltage to just below 54 VAC.
26. Verify that Breaker 52-1 trips.
27. Return the variable voltage source to 120 VAC.
28. Re-enable the 27-1 element in the 13.8 kV Primary Relay.

IV. Test Tripping- 13.8 kV Primary Relay 59 Elements

Purpose: To verify the operation of the 59 overvoltage tripping elements in the 13.8 kV Primary Relay.

1. Connect a variable voltage source to the voltage terminals of the 13.8 kV Primary Relay.
2. Set the variable voltage source to 120 VAC.
3. Close Breaker 52-1.

4. Raise the Phase A voltage to just above 132 VAC.
5. Verify that Breaker 52-1 trips.
6. Return the variable voltage source to 120 VAC.
7. Close Breaker 52-1.
8. Raise the Phase B voltage to just above 132 VAC.
9. Verify that Breaker 52-1 trips.
10. Return the variable voltage source to 120 VAC.
11. Close Breaker 52-1.
12. Raise the Phase C voltage to just above 132 VAC.
13. Verify that Breaker 52-1 trips.
14. Return the variable voltage source to 120 VAC.
15. Close Breaker 52-1.
16. Disable the 59-1 element in the 13.8 kV Primary Relay.
17. Raise the Phase A voltage to just above 144 VAC.
18. Verify that Breaker 52-1 trips.
19. Return the variable voltage source to 120 VAC.
20. Close Breaker 52-1.
21. Raise the Phase B voltage to just above 144 VAC.
22. Verify that Breaker 52-1 trips.
23. Return the variable voltage source to 120 VAC.
24. Close Breaker 52-1.
25. Raise the Phase C voltage to just above 144 VAC.
26. Verify that Breaker 52-1 trips.
27. Return the variable voltage source to 120 VAC.
28. Re-enable the 59-1 element in the 13.8 kV Primary Relay.

V. Test Tripping- 13.8 kV Primary Relay 51N Element

Purpose: To verify the operation of the 51N ground time overcurrent tripping element in the 13.8 kV Primary Relay

1. Connect a variable current source to the neutral current terminal of the 13.8 kV Primary Relay.
2. Set the variable current source to 0 A.
3. Close Breaker 52-1.
4. Close Breaker 52-2
5. Raise the current to just above 5 A.
6. Verify that Breaker 52-1 trips.
7. Verify that Breaker 52-2 trips.

VI. Test Tripping- 13.8 kV Backup Relay Elements

Purpose: To verify the operation of the protective elements in the 13.8 kV Backup Relay.

1. Repeat the steps in Sections III – V using the 13.8 kV Backup Relay.

VII. Test Tripping- 4.16 kV Primary Relay 81U Elements

Purpose: To verify the operation of the 81U underfrequency tripping elements in the 4.16 kV Primary Relay.

1. Connect a variable frequency source to the voltage terminals of the 4.16 kV Primary Relay.
2. Set the variable frequency source to 60 Hz.
3. Close Breaker 52-2.
4. Lower the frequency to just below 59.0 Hz.
5. Verify that Breaker 52-2 trips.
6. Return the variable frequency source to 60 Hz.
7. Close Breaker 52-2.
8. Disable the 81U-1 element in the 4.16 kV Primary Relay.
9. Lower the frequency to just below 57.0 Hz.
10. Verify that Breaker 52-2 trips.
11. Return the variable frequency source to 60 Hz.
12. Re-enable the 81U-1 element in the 4.16 kV Primary Relay.

VIII. Test Tripping- 4.16 kV Primary Relay 81O Elements

Purpose: To verify the operation of the 81O overfrequency tripping elements in the 4.16 kV Primary Relay.

1. Connect a variable frequency source to the voltage terminals of the 4.16 kV Primary Relay.
2. Set the variable frequency source to 60 Hz.
3. Close Breaker 52-2.
4. Raise the frequency to just above 61.0 Hz.
5. Verify that Breaker 52-2 trips.
6. Return the variable frequency source to 60 Hz.
7. Close Breaker 52-2.
8. Disable the 81O-1 element in the 4.16 kV Primary Relay.
9. Raise the frequency to just above 61.8 Hz.
10. Verify that Breaker 52-2 trips.
11. Return the variable frequency source to 60 Hz.
12. Re-enable the 81O-1 element in the 4.16 kV Primary Relay.

IX. Test Tripping- 4.16 kV Primary Relay 51V Element

Purpose: To verify the operation of the 51V voltage-restrained overcurrent tripping element in the 4.16 kV Primary Relay.

1. Connect a variable voltage source to the voltage terminals of the 4.16 kV Primary Relay.
2. Set the variable voltage source to 0 VAC.

3. Connect a variable current source to the current terminals of the 4.16 kV Primary Relay.
4. Set the variable current source to 0 A.
5. Close Breaker 52-2.
6. Raise the Phase A current to just above 5 A.
7. Verify that Breaker 52-2 trips.
8. Return the Phase A current to 0 A.
9. Close Breaker 52-2.
10. Raise the Phase B current to just above 5 A.
11. Verify that Breaker 52-2 trips.
12. Return the Phase B current to 0 A.
13. Close Breaker 52-2.
14. Raise the Phase C current to just above 5 A.
15. Verify that Breaker 52-2 trips.
16. Return the Phase C current to 0 A.

X. Test Tripping- 4.16 kV Primary Relay 46 Element

Purpose: To verify the operation of the 46 negative-sequence time overcurrent tripping element in the 4.16 kV Primary Relay.

1. Connect a variable current source to the current terminals of the 4.16 kV Primary Relay.
2. Set the variable current source to 0 A.
3. Close Breaker 52-2.
4. Raise the Phase A current to just above 30 A.
5. Verify that Breaker 52-2 trips.

XI. Test Tripping- 4.16 kV Backup Relay Elements

Purpose: To verify the operation of the protective elements in the 4.16 kV Backup Relay.

1. Repeat the steps in Sections VII – X using the 13.8 kV Backup Relay.

XII. Phase Loss Detection

Purpose: To simulate an open conductor condition on the Central Hudson system and to verify that a trip will occur for this condition.

1. Close Switch 89-1.
2. Close Breaker 52-1.
3. Using generator automatic control system, allow generator to come up to speed and synchronize with the Central Hudson system.
4. Bring generator up to half power.
5. Request Central Hudson line crew to open the Phase A cutout on Pole #XXXXXXX.

6. Verify that Breaker 52-1 trips.
7. Verify that Breaker 52-2 trips.
8. Request Central Hudson line crew to replace the Phase A cutout on Pole #XXXXXX.

XIII. Direct Transfer Trip

Purpose: To verify the operation and connection of the DTT scheme.

1. Close Breaker 52-1.
2. Request DTT signal to be sent from the Central Hudson Substation.
3. Verify that Breaker 52-1 trips.
4. Verify that, while DTT signal is being received from the Central Hudson Substation, Breaker 52-1 cannot be closed.

XIV. Breaker Failure Protection- Breaker 52-1

Purpose: To verify that the generator disconnects from the Central Hudson system in the event that Breaker 52-1 fails to trip.

1. Open the isolation test switches for the 13.8 kV Primary Relay Trip output to Breaker 52-1.
2. Open the isolation test switches for the 13.8 kV Backup Relay Trip output to Breaker 52-1.
3. Connect a variable voltage source to the voltage terminals of the 13.8 kV Primary Relay.
4. Set the variable voltage source to 120 VAC.
5. Close Breaker 52-1.
6. Close Breaker 52-2.
7. Lower the Phase A voltage to just below 105.6 VAC.
8. Verify that Breaker 52-1 does not trip.
9. Verify that Breaker 52-2 trips.
10. Return the variable voltage source to 120 VAC.
11. Close the isolation test switches for the 13.8 kV Primary Relay Trip output to Breaker 52-1.
12. Close the isolation test switches for the 13.8 kV Backup Relay Trip output to Breaker 52-1.

XV. Breaker Failure Protection- Breaker 52-2

Purpose: To verify that the generator disconnects from the Central Hudson system in the event that Breaker 52-2 fails to trip.

1. Open the isolation test switches for the 4.16 kV Primary Relay Trip output to Breaker 52-2.
2. Open the isolation test switches for the 4.16 kV Backup Relay Trip output to Breaker 52-2.

3. Connect a variable frequency source to the voltage terminals of the 4.16 kV Primary Relay.
4. Set the variable frequency source to 60 Hz.
5. Close Breaker 52-2.
6. Lower the frequency to just below 59.0 Hz.
7. Verify that Breaker 52-2 does not trip.
8. Verify that Breaker 52-1 trips.
9. Return the variable frequency source to 60 Hz.
10. Close the isolation test switches for the 4.16 kV Primary Relay Trip output to Breaker 52-2.
11. Close the isolation test switches for the 4.16 kV Backup Relay Trip output to Breaker 52-2.

XVI. Reconnect Timer Test

Purpose: To verify that the generator cannot be reconnected to the Central Hudson system for 5 minutes after good voltage is restored following a fault condition.

1. Connect a variable voltage source to the voltage terminals of the 13.8 kV Primary Relay.
2. Set the variable voltage source to 120 VAC.
3. Close Breaker 52-1.
4. Lower the Phase A voltage to just below 105.6 VAC.
5. Verify that Breaker 52-1 trips.
6. Verify that Breaker 52-1 cannot be closed.
7. Return the variable voltage source to 120 VAC.
8. Verify that Breaker 52-1 cannot be closed.
9. Wait 5 minutes from the time of the voltage source return to 120 VAC.
10. Close Breaker 52-1.

XVII. Phase Angle Tests

Purpose: To verify generator current and voltage connections in protective relays.

1. Open Breaker 52-1.
2. Allow generator control scheme and automatic synchronizing device to bring generator up to speed, frequency, and voltage.
3. Close Breaker 52-1.
4. Verify and record the current and voltage phasing measurements at the 13.8 kV Primary, 13.8 kV Backup, 4.16 kV Primary, and 4.16 kV Backup Relays.

Figure 7- Example of a Functional Test Procedure for the Figure 3 One-Line Diagram

Note: Prior to the functional test being performed, preliminary testing will have been completed on all protective relays and other equipment.

I. Protective Device Settings.

Notes:

All settings will have been uploaded onto the protective devices prior to the functional tests. Factory test reports for all devices shall be submitted to Central Hudson prior to the functional tests.

Inverter:

Element	Setting
27-1 Pickup	195.6 V secondary
27-1 Time Delay	2 seconds
27-2 Pickup	100.0 V secondary
27-2 Time Delay	0.16 seconds
59-1 Pickup	244.5 V secondary
59-1 Time Delay	1 second
59-2 Pickup	266.7 V secondary
59-2 Time Delay	0.16 seconds
81U-1 Pickup	59.0 Hz
81U-1 Time Delay	300 seconds
81U-2 Pickup	57.0 Hz
81U-2 Time Delay	0.16 seconds
81O-1 Pickup	61.0 Hz
81O-1 Time Delay	180 seconds
81O-2 Pickup	61.8 Hz
81O-2 Time Delay	0.16 seconds

SEL-651R Relay:

Element	Setting
27-1 Pickup	195.6 V secondary
27-1 Time Delay	10 seconds
27-2 Pickup	100.0 V secondary
27-2 Time Delay	2 seconds
59-1 Pickup	244.5 V secondary
59-1 Time Delay	10 seconds
59-2 Pickup	266.7 V secondary
59-2 Time Delay	2 seconds
81U Pickup	57 Hz
81U Time Delay	1 second

81O Pickup	61.8 Hz
81O Time Delay	1 second
50G Pickup	0.05 A secondary
50G Time Delay	2 seconds
50Q Pickup	0.052 A secondary
50Q Time Delay	2 seconds
59N Pickup	2.34 V secondary
59Q Pickup	2.00 V secondary

II. Relay Output Verification

1. Review the SEL-651R Relay settings file. Verify that the applicable settings above are mapped to the Trip output contact(s).

III. Initial Setup

1. Close Switch 89-1.
2. Close Recloser 52-1.
3. Connect the inverter(s).

IV. Three Phase Loss Detection

Purpose: To simulate a three-phase utility outage on the Central Hudson system and to verify that a trip will occur for this condition.

1. Verify that inverter has started successfully and exports power.
2. Open Switch 89-1.
3. Verify that Recloser 52-1 trips.
4. Verify that inverter shuts down.
5. Close Switch 89-1.
6. Verify that recloser cannot be closed.
7. Wait 5 minutes from the time of Switch 89-1 closing.
8. Close Recloser 52-1.
9. Verify that inverter starts successfully and exports power.

V. Single Phase Loss Detection

Purpose: To simulate a single open conductor on the Central Hudson system and to verify that a trip will occur for this condition.

1. Verify that inverter has started successfully and exports power.
2. Disconnect single phase upstream of Recloser 52-1.
3. Verify that Recloser 52-1 trips.
4. Verify that inverter shuts down.
5. Reconnect single phase upstream of Recloser 52-1

6. Verify that recloser cannot be closed for at least 5 minutes after the phase has been restored.
7. Close Recloser 52-1.
8. Verify that inverter starts successfully and exports power.
9. Repeat steps 1-8 for each phase.

VI. Phase Angle Tests

Purpose: To verify generator current and voltage connections in the SEL-651R Relay.

1. Verify that inverter has started successfully and exports power.
2. Verify and record the current and voltage phasing measurements at the SEL-651R Relays.

Figure 8- Examples of Effective Grounding Configurations

Wye Grounded-Delta Grounding Bank

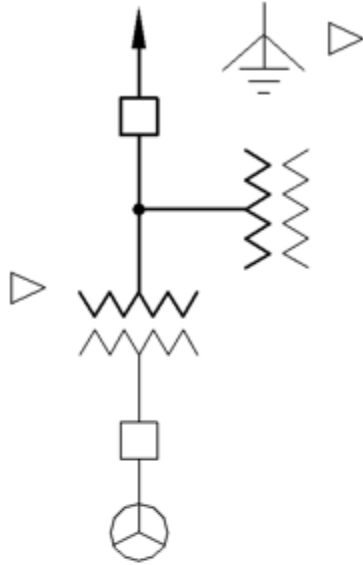

Zig-Zag Grounding Bank

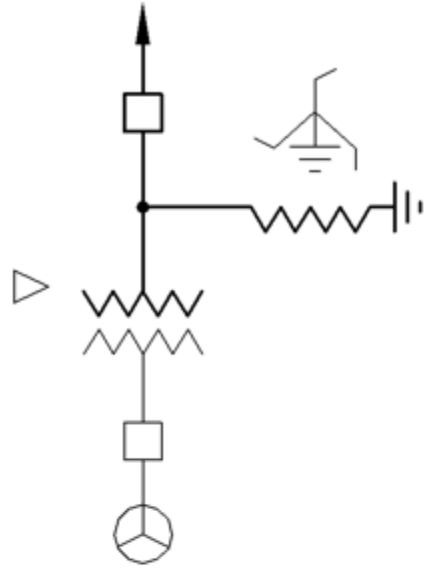

Wye Grounded-Wye Grounded Step-Up
Wye Grounded Generator

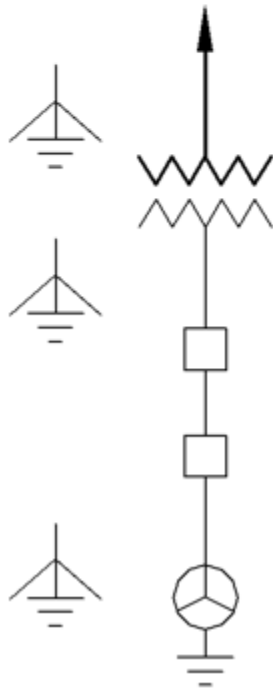

Delta-Wye Grounded Step-Up

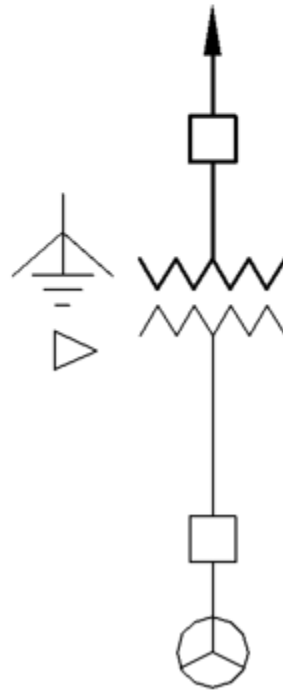
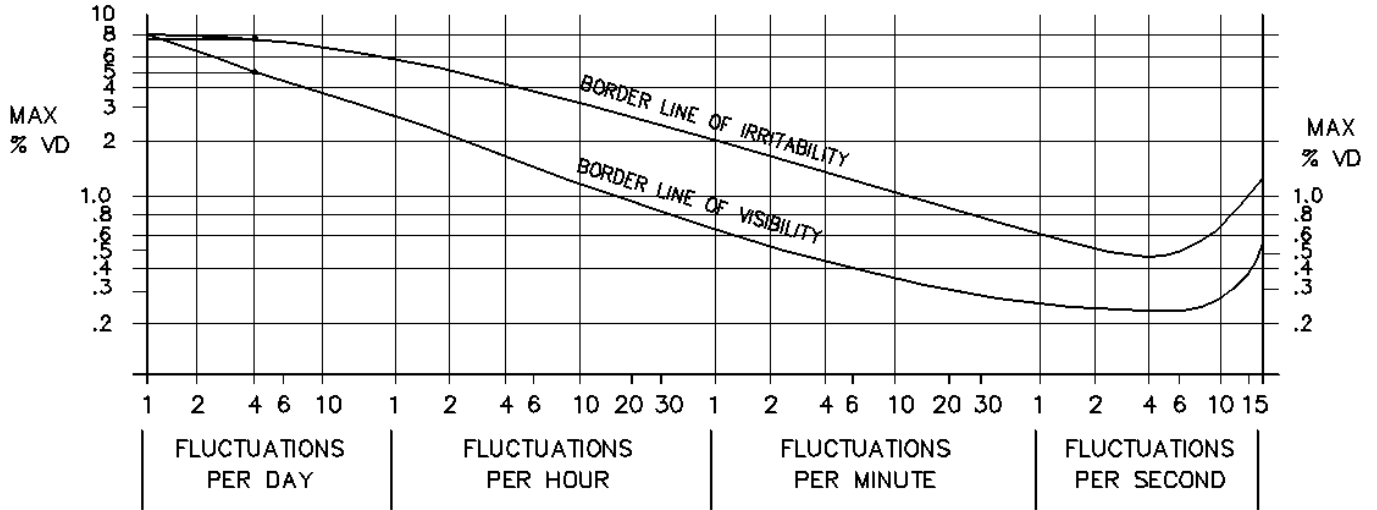

Figure 9- GE Flicker Curve

CENTRAL HUDSON
MAX % VD VERSUS FREQUENCY OF FLUCTUATION



Notes:

1. Any voltage drop above 8% is not acceptable.
2. Maximum voltage drop shall be below the 'Border Line of Visibility' curve.

Figure 10- Example of Required Monitoring and Control for Inverter-Based DER Sites without a PCC Recloser

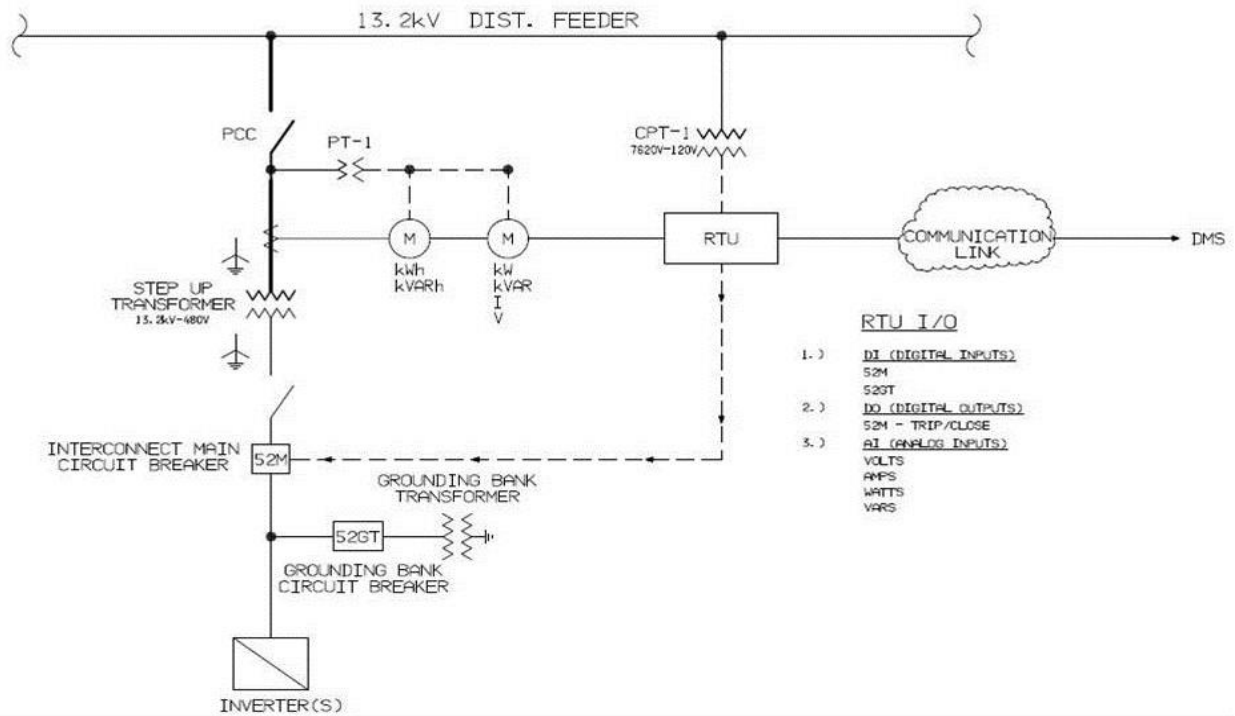

Table 1- Resource Interconnection Study Jurisdiction Table

Intended Market	Interconnection Point	Project Size	Study Process
Wholesale	NYS Transmission System or Distribution subject to NYISO's OATT Interconnection Procedures	> 5MW	NYISO
		≤ 5MW	NYISO
	Distribution not subject to NYISO's OATT Interconnection Procedures	> 5MW	Utility
		≤ 5MW	SIR
Retail	NYS Transmission System	Any Size	Utility
	Distribution	> 5MW	Utility
		≤ 5MW	SIR

Table 2- Interconnection Equipment Data Sheets

Customer:

Name: _____ Phone: (____) _____

Address: _____ Municipality: _____
_____**Consulting Engineer or Contractor:**

Name: _____ Phone: (____) _____

Address: _____
_____**Estimated In-Service Date:** _____**Existing Electric Service:**

Capacity: _____ Amperes Voltage: _____ Volts

Service Character: ()Single Phase ()Three Phase

Secondary 3 Phase Transformer Connection ()Wye ()Delta

Transformer Impedance _____ %Z

Transformer Nameplate Rating _____ kVA

New Electric Service (If Applicable):

Capacity: _____ Amperes Voltage: _____ Volts

Service Character: ()Single Phase ()Three Phase

Secondary 3 Phase Transformer Connection ()Wye ()Delta

Transformer Impedance _____ %Z

Transformer Nameplate Rating _____ kVA

Location of Protective Interface Equipment on Property:(include address if different from customer address)
_____**Energy Producing Equipment/Inverter Information:**

Manufacturer: _____

Model No. _____ Version No. _____

()Synchronous ()Induction ()Inverter ()Other _____

Rating: _____ kW Rating: _____ kVA

Rated Output: _____ VA Rated Voltage: _____ Volts

Rate Frequency: _____ Hertz Rated Speed: _____ RPM

Efficiency: _____ % Power Factor: _____ %

Rated Current: _____ Amps Locked Rotor Current: _____ Amps

Synchronous Speed: _____ RPM Winding Connection:

Min. Operating Freq./Time:

Generator Connection: ()Delta ()Wye ()Wye Grounded

System Type Tested (Total System): ()Yes ()No; attach product literature

Equipment Type Tested (i.e. Inverter, Protection System):

()Yes ()No; attach product literature

One Line Diagram attached: ()Yes

Installation Test Plan attached: () Yes

For Synchronous Machines:

Submit copies of the Saturation Curve and the Vee Curve
() Salient () Non-Salient
Torque: _____ lb-ft Rated RPM: _____
Field Amperes: _____ at rated generator voltage and current
and _____ % PF over-excited
Type of Exciter: _____
Output Power of Exciter: _____
Type of Voltage Regulator: _____
Direct-axis Synchronous Reactance (X_d) _____ ohms
Direct-axis Transient Reactance (X'_d) _____ ohms
Direct-axis Sub-transient Reactance (X''_d) _____ ohms
Quadrature-axis Synchronous Reactance (X_q) _____ ohms
Quadrature-axis Transient Reactance (X'_q) _____ ohms
Quadrature-axis Sub-transient Reactance (X''_q) _____ ohms
Zero Sequence Reactance (X_0) _____ ohms
Negative Sequence Reactance (X_2) _____ ohms
Field Winding Open Circuit Transient Time Constant (T') _____ seconds
Field Winding Short Circuit Transient Time Constant (T'') _____ seconds
Field Winding Short Circuit Subtransient Time Constant (T''') _____ seconds
Armature Winding Transient Time Constant (with field winding shorted) (T') _____ seconds
Damper (Amoritisneur) Winding? () Yes () No
Neutral Grounded () No () Yes _____ ohms (resistive) _____ ohms (reactive)

For Induction Machines:

Rotor Resistance (R_r) _____ ohms Exciting Current _____ Amps
Rotor Reactance (X_r) _____ ohms Reactive Power Required:
Magnetizing Reactance (X_m) _____ ohms _____ VARs (No Load)
Stator Resistance (R_s) _____ ohms _____ VARs (Full Load)
Stator Reactance (X_s) _____ ohms
Short Circuit Reactance (X''_d) _____ ohms Phases:
Frame Size: _____ Design Letter: _____ () Single
Temp. Rise: _____ °C. () Three-Phase
Neutral Grounded () No () Yes _____ ohms (resistive) _____ ohms (reactive)

For Inverters:

Manufacturer: _____ Model:
Commutation Method: () Self Commutated () Line Commutated
Interconnection Type: () Utility Interactive () Standalone
Rated Output: _____ Amps _____ Volts
Efficiency: _____ %
Current-carrying neutral wire? () Yes () No
Positive Sequence Impedance (Z_1) _____ ohms
Negative Sequence Impedance (Z_2) _____ ohms
Zero Sequence Impedance (Z_0) _____ ohms
Available Grid Support Functions: _____

For Energy Storage:

Manufacturer: _____ Model:
Type: () NaS () Dry Cell () PB-acid () Lithium-Ion () Vanadium flow () Other
Rated Output: _____ kW _____ kWh
Efficiency: _____ %
Power Factor Range: _____ () Single Quadrant () Two-Quadrant () Four-Quadrant
Available Grid Support Functions: _____

Current-carrying neutral wire? () Yes () No
Positive Sequence Impedance (Z_1) _____ ohms
Negative Sequence Impedance (Z_2) _____ ohms
Zero Sequence Impedance (Z_0) _____ ohms

Signature:

CUSTOMER SIGNATURE

TITLE

DATE

Table 3- Identification of “FAIL SAFE” Interconnection Protection Scheme

Central Hudson System Disturbances				
Abnormal Condition	Primary Protection		Back-Up Protection	
	Sensing Element	Disconnecting Device	Sensing Element	Disconnecting Device
Phase-Ground Fault				
Two Phase-Ground Fault				
Phase-Phase Fault				
Three Phase Fault				
Open Conductor				

Isolation With Part of the Central Hudson System				
Abnormal Condition	Primary Protection		Back-Up Protection	
	Sensing Element	Disconnecting Device	Sensing Element	Disconnecting Device
Generation Less Than Load				
Generation Greater Than Load				