

NYCA IRM Requirement Study 2024-2025 Preliminary Base Case (PBC) Model Assumptions Matrix

Draft V3.0

NYSRC

Installed Capacity Subcommittee Meeting #277

May 30, 2023

Load Forecast

#	Parameter	2023 Model Assumptions	2024 Model Assumptions	Basis for Recommendation	Model Change
1	Peak Load Forecast (Preliminary Base Case – Parametric & Sensitivities)	2022 Gold Book NYCA: 32,018 MW ² NYC: 11,001 MW LI: 5,031 MW G-J: 15,223 MW (Attachment A1)	2023 Gold Book NYCA: 32,451.5 MW ¹ NYC: 11,303 MW LI: 5090.1 MW G-J: 15,439 MW (Attachment A1)	Most recent Gold Book Forecast is used for Preliminary Base Case parametric study and sensitivity cases	N
2	Peak Load Forecast (Final Base Case)	October 2022 Fcst. NYCA: 32,246 MW ¹ NYC: 11,285 MW LI: 5,133 MW G-J: 15,407 MW	(Expected October 2022)	Updated Load Forecast in October will be used for Final Base Case	
3	Load Shape (Multiple Load Shape)	Bin 1-2: 2013 Bin 3-4: 2018 Bin 5-7: 2017	Bin 1-2: 2013 Bin 3-4: 2018 Bin 5-7: 2017	ICS Recommendation	N
4	Load Forecast Uncertainty (LFU)	Zonal Model to reflect current data with input from Con Ed and LIPA. (Attachment A2)			
5	LFU Winter	Attachment A3			

¹ BTM-NG loads have been incorporated into these numbers.

² The loads associated with the BTM:NG program need to be added to these values.

Generation Parameters

#	Parameter	2023 Model Assumptions	2024 Model Assumptions	Basis for Recommendation	Model Change
6	Existing Generating Unit Capacities	2022 Gold Book Values. Use min. (DMNC vs. CRIS) capacity value	2023 Gold Book Values. Use min. (DMNC vs. CRIS) capacity value	Latest Gold Book publication	N
7	Proposed New Units (Thermal) and re-ratings	0 MW of new Thermal resources (Attachment B1)	0 MW of new Thermal resources (Attachment B1)	NYISO recommendation based on documented process that includes the latest Gold Book publication, NYISO interconnection queue, and generation notifications	N
8	Deactivations and Removals ³	1,331.2 MW unit deactivations (Attachment B2)	-151.8 MW unit deactivations (Attachment B2)	Latest Gold Book publications and generator notifications	N
9	Forced and Partial Outage Rates	Five-year (2017-2021) GADS data for each unit represented. Those units with less than five years – use representative data. (Attachment C)	Five-year (2018-2022) GADS data for each unit represented. Those units with less than five years – use representative data. (Attachment C)	Transition Rates representing the Equivalent Forced Outage Rates (EFORd) during demand periods over the most recent five-year period	N
10	Planned Outages	Based on schedules received by the NYISO and adjusted for history	Based on schedules received by the NYISO and adjusted for history	Updated schedules	

Generation Parameters

#	Parameter	2023 Model Assumptions	2024 Model Assumptions	Basis for Recommendation	Model Change
11	Summer Maintenance	Nominal 50 MWs – divided equally between Zones J and K	<i>(Expected August 2022)</i>	Review of most recent data	
12	Combustion Turbine Derates	Derate based on temperature correction curves provided	Derate based on temperature correction curves provided	Operational history indicates the derates are in line with manufacturer's provided curves	N
13	Existing and Proposed New Wind Units ⁴	539.3 MW of Wind Capacity additions totaling 2351.1 MW of qualifying wind (Attachment B3)	136 MW of off-shore Wind Capacity additions totaling 2502.3 MW of qualifying wind (Attachment B3)	ICAP units based on RPS agreements, interconnection queue and ICS input.	Y
14	Wind Shape	Actual hourly plant output over the period 2017-2021. New units will use zonal hourly averages or nearby units	Actual hourly plant output over the period 2018-2022. New units will use zonal hourly averages or nearby units	Program randomly selects a wind shape of hourly production from the most recent five-year period for each model iteration.	N
15	Existing and Proposed New Solar Resources ⁴	0 MW of Solar Capacity additions totaling 214.4 MW of qualifying Solar Capacity. (Attachment B3)	90 MW of Solar Capacity additions totaling 304.4 MW of qualifying Solar Capacity. (Attachment B3)	ICAP units based on RPS agreements, interconnection queue and ICS input.	N
16	Solar Shape	Actual hourly plant output over the period 2017-2021. New units will use zonal hourly averages or nearby units	Actual hourly plant output over the period 2018-2022. New units will use zonal hourly averages or nearby units	Program randomly selects a solar shape of hourly production from the most recent five-year period for each model iteration.	N

Generation Parameters

#	Parameter	2023 Model Assumptions	2024 Model Assumptions	Basis for Recommendation	Model Change
17	BTM- NG Program	No new BTM NG resources, for 161.6 MW (Attachment B5)	No new BTM NG resources, for 171.5 MW (Attachment B5)	Both the generation of the participating resources and the full host loads are modeled.	N
18	Small Hydro Resources	Actual hourly plant output over the period 2017-2021.	Actual hourly plant output over the period 2018-2022.	Program randomly selects a hydro shape of hourly production from the most recent five-year period for each model iteration.	N
19	Large Hydro	Probabilistic Model based on five years of GADS data (2017-2021)	Probabilistic Model based on five years of GADS data (2018-2022)	Transition Rates representing the Equivalent Forced Outage Rates (EFORd) during demand periods over the most recent five-year period.	N
20	Landfill Gas	Actual hourly plant output over the period 2017-2021.	Actual hourly plant output over the period 2018-2022.	Program randomly selects an LFG shape of hourly production from the most recent five-year period for each model iteration.	N
21	New ESR (Energy Storage Resources) ⁴	20 MW of new battery storage scheduled. 20 MW of total battery storage modeled (see attachment B4)	0 MW of new battery storage scheduled. 20 MW of total battery storage modeled	ICAP units based on RPS agreements, interconnection queue and ICS input.	N
22	Energy Limited Resources (ELR)	Based upon elections made by August 1 st , 2022	(Updated elections expected August 2023)	Existing elections are made by August 1 st and will be incorporated into the model. Elected ELR units will be modeled using the GE MARS ELR functionalities	

Transactions- Imports and Exports

#	Parameter	2023 Model Assumptions	2024 Model Assumptions	Basis for Recommendation	Model Change
23	Capacity Purchases	Existing Rights: PJM – 1,080 MW HQ – 1,190 MW All contracts modeled as equivalent contracts.	Existing Rights: PJM – 1,013 MW HQ – 1,190 MW All contracts modeled as equivalent contracts.	Grandfathered Rights, ETCNL, and other awarded long-term rights	N
24	Capacity Sales	Long Term firm sales Summer 265.4 MW	Long Term firm sales Summer 265.3 MW	These are long term FERC-approved contracts.	N
25	FCM Sales from a Locality ³	No sales modeled within study period	No sales modeled within study period	White paper, NYISO recommendation	N
26	Wheels through NYCA	300 MW HQ to NE equivalent contract	300 MW HQ to NE equivalent contract	HQ Wheel has an ISO-NE capacity supply obligation (CSO) for 2024-25	N
27	New UDRs (Unforced capacity Deliverability Rights)	No new UDRs Identified	No new UDRs Identified	Existing UDR elections are made by August 1 st and will be incorporated into the model	N
28	New EDRs (External Deliverability Rights)	No new EDRs Identified	No new EDRs Identified	Existing EDRs are incorporated in the model as an increase in the transfer limits	N

³ Final FCM sales that will materialize are unknowable at the time of the IRM study. To reflect the impact these sales have on reliability, the NYISO applies a Locality Exchange Factor in the market.

Topology

#	Parameter	2023 Model Assumptions	2024 Model Assumptions	Basis for Recommendation	Model Change
29	Interface Limits	Central East forward and Group limit updates due to AC Transmission Segment A, Neptune no longer derated unless further delay in return to full service, UPNY-ConED series reactors in service, West Central Reverse uprate External transfer limits update , Zone K export Transfer Limit update	Updates to the forward limits of Central East, Central East Group ,Marcy South, Capital to Hudson Valley, UPNYSENY, and UPNY-ConEd interfaces due to the full in service of AC Transmission Project.	Based on the most recent NYISO studies and processes, such as Operating Study, Operations Engineering Voltage Studies, Comprehensive System Planning Process, and additional analysis including interregional planning initiatives	Y
30	New Transmission	None Identified	None Identified	Based on TO provided models and NYISO's review	N
31	AC Cable Forced Outage Rates	All existing Cable EFORDs for NYC and LI to reflect most recent five-year history (2017-2021) (Attachment E4)	All existing Cable EFORDs for NYC and LI to reflect most recent five-year history (2018-2022) (Attachment E4)	TO provided transition rates with NYISO review	N
32	UDR Line Unavailability	Five year history of forced outages (2017-2021)	Five year history of forced outages (2018-2022)	NYISO/TO review	N

Emergency Operating Procedures

#	Parameter	2023 Model Assumptions	2024 Model Assumptions	Basis for Recommendation	Model Change
33	Special Case Resources	July 2022 –1224 MW based on registrations and modeled as 860 MW of effective capacity. Monthly variation based on historical experience.			
34	Other EOPs	350 MW of 10-min Operating Reserve maintained at Load Shedding 858.4 MW of non-SCR/non-EDRP resources (Attachment D)	400 MW of 10-min Operating Reserve maintained at Load Shedding (Expected August 2023) ___ MW of non-SCR/non-EDRP resources	Based on Whitepaper and NYISO updated analysis recommendation Based on TO information, measured data, and NYISO forecasts	N
35	EOP Structure	10 EOP steps modeled	10 EOP steps modeled	Based on agreement with ICS	N

External Control Areas

#	Parameter	2023 Model Assumptions	2024 Model Assumptions	Basis for Recommendation	Model Change
36	PJM	Load and Capacity data will be provided by ISONE/NPCC CP-8 Data may be adjusted per NYSRC Policy 5 (Attachment E)	Load and Capacity data will be provided by ISONE/NPCC CP-8 Data may be adjusted per NYSRC Policy 5 (Attachment E)	Initial Review performed by the NPCC CP-8 WG prior to Policy 5 changes	N
37	ISONE, Quebec, IESO	Load and Capacity data will be provided by ISONE/NPCC CP-8 Data adjusted per NYSRC Policy 5 (Attachment E)	Load and Capacity data will be provided by ISONE/NPCC CP-8 Data adjusted per NYSRC Policy 5 (Attachment E)	Initial Review performed by the NPCC CP-8 WG prior to Policy 5 changes	N
38	External Adjustments per Policy 5	If needed, add load to externals proportional to existing excess capacity	If needed, add load to externals proportional to existing excess capacity	Whitepaper on External Control Area adjustments	N
39	Reserve Sharing	All NPCC Control Areas indicate that they will initially share reserves equally among all members and then among non-members	All NPCC Control Areas indicate that they will initially share reserves equally among all members and then among non-members	Per NPCC CP-8 WG	N
40	Emergency Assistance	Statewide Limit of 3,500 MW of emergency assistance allowed from neighbors.	Statewide Limit of 3,500 MW of emergency assistance allowed from neighbors.	White Paper on Modelling of Emergency Assistance for NYCA in IRM studies	N

Miscellaneous

#	Parameter	2023 Model Assumptions	2024 Model Assumptions	Basis for Recommendation	Model Change
41	MARS Model Version	4.10.2035	4.13.2129	Per testing and ICS recommendation	Y
42	Environmental Initiatives	No new rules for 2023 Capability Year	<i>(Expected July 2023)</i>		

Attachment A1

NYCA Summer Load Forecast Coincident and Non-Coincident Peak: 2023 FBC and 2024 PBC

2023 FBC													
Area	A	B	C	D	E	F	G	H	I	J	K	NYCA	G_J
NCP - Forecast	2824.6	2032.7	2843.6	715.4	1393.6	2477.1	2147.8	646.3	1424.4	11285	5133.3		
CP - Forecast	2733	1990.1	2775.5	695	1355.7	2441.5	2105.5	633.9	1397	11068.5	5050.3	32246	
G-J Peak - Forecast							2133.5	642.2	1415.6	11215.5			15406.8

2024 PBC													
Area	A	B	C	D	E	F	G	H	I	J	K	NYCA	G_J
NCP - Forecast	2791	2237.1	2851.3	712	1468	2453	2180	632	1424	11303	5090.1		
CP - Forecast	2701	2190.1	2783.3	692	1428	2412	2137	620	1397	11083	5008.1	32451.5	
G-J Peak - Forecast							2165	628	1416	11230			15439

Delta													
Area	A	B	C	D	E	F	G	H	I	J	K	NYCA	G_J
NCP - Forecast	-33.6	204.4	7.7	-3.4	74.4	-24.1	32.2	-14.3	-0.4	18	-43.2		
CP - Forecast	-32	200	7.8	-3	72.3	-29.5	31.5	-13.9	0	14.5	-42.2	205.5	
G-J Peak - Forecast							31.5	-14.2	0.4	14.5			32.2

Attachment A2

NYCA Summer Load Forecast Uncertainty Model: 2023 and 2024

Load Forecast 2023

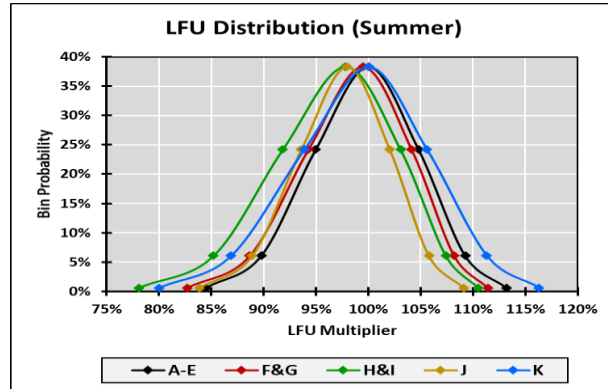

Bin	Bin z	Bin Probability	A-E	F&G	H&I	J	K
Bin 1	2.74	0.62%	113.18%	111.42%	110.50%	109.10%	116.30%
Bin 2	1.79	6.06%	109.25%	108.20%	107.41%	105.78%	111.32%
Bin 3	0.89	24.17%	104.80%	104.14%	103.08%	102.05%	105.60%
Bin 4	0.00	38.29%	100.00%	99.46%	97.82%	97.98%	100.00%
Bin 5	-0.89	24.17%	94.96%	94.28%	91.83%	93.60%	93.87%
Bin 6	-1.79	6.06%	89.75%	88.67%	85.21%	88.90%	86.89%
Bin 7	-2.74	0.62%	84.49%	82.72%	78.09%	83.89%	80.04%

Attachment A3

NYCA Winter Load Forecast Uncertainty Model: 2023

Bin	Bin z	Bin Probability	NYCA
Bin 1	2.74	0.62%	110.29%
Bin 2	1.79	6.06%	106.26%
Bin 3	0.89	24.17%	102.65%
Bin 4	0.00	38.29%	99.37%
Bin 5	-0.89	24.17%	96.32%
Bin 6	-1.79	6.06%	93.46%
Bin 7	-2.74	0.62%	90.74%

Attachment B1

New Thermal Units and Unit Re-Ratings

New Thermal Units and Unit Re-ratings (summer ratings)					
Project or Generator Name	Zone	2023 Gold Book (MW) CRIS	2023 Gold Book (MW) DMNC	New or Incremental (MW)	2024 MARS Model (MW)
New Units					
Total New Units and Uprates (MW)					

Attachment B2

Deactivations and Removals

Unit Removal since 2023-2024 IRM Study			
Generator Name	Type	Zone	SUMMER CRIS (MW)
Coxsackie GT	GT	G	-19.0
South Cairo	GT	G	-18.7
Astoria GT 01	GT	J	-13.4
Glenwood GT 03	GT	K	-49.9
Shoreham 1	GT	K	-41.3
Shoreham 2	GT	K	-16.5
Total Removals			-158.8

Note: Negative values in the 'SUMMER CRIS (MW)' column represent units that were previously expected to deactivate but are no longer doing so due to the 2023 Peaker Rules. Therefore, they will be reinstated in the 2024-25 IRM Study.

Attachment B3

New Intermittent Resources

New Intermittent Units				
Resource	Zone	CRIS (MW)	Summer Capability (MW)	MARS Modeled Capacity
Wind				
South Fork Wind Farm (Off-Shore)	K	96.0	96.0	96.0
South Fork Wind Farm II (Off-Shore)	K	40.0	40.0	40.0
Total Wind				136.0
Solar				
Albany County	F	20.0	20.0	20.0
Albany County II	F	20.0	20.0	20.0
East Point Solar	F	50.0	50.0	50.0
Total Solar				90.0

Attachment B4

New Energy Storage Resources

Energy Storage				
Resource	Zone	CRIS (MW)	Summer Capability (MW)	Lesser of Summer Capability VS CRIS
New Battery Units				
Total New Energy Storage				

Attachment B5

Resources in the Behind the Meter Net Generation Program (BTM-NG)

Attachment B5 - Units in the Behind the Meter Net Generation Program*			
Generator Name	Zone	Resource Value (MW) ⁴	Peak Load Adjustment (MW) ⁵
Existing:			
Stony Brook	K	40.7	41.1
Greenidge 4	C	86.6	52.3
Lyons Falls Hydro	E	0.0	2.0
KIAC_JFK	J	126.3	23.0
Red Rochester	B	76.2	53.1
Total BTM-NG			171.5

*The IRM study independently models the generation and load components of BTM:NG Resources.

⁴ Based on adjusted Dependable Maximum Gross Capability (DMGC) value.

⁵ Based on Average Coincident Host Load (ACHL).

*** One existing resource in Zone J is expected to begin participating in the BTM:NG program in Summer 2022

Attachment C

NYCA Five Year Derating Factors

New York 5 Year EFORDs

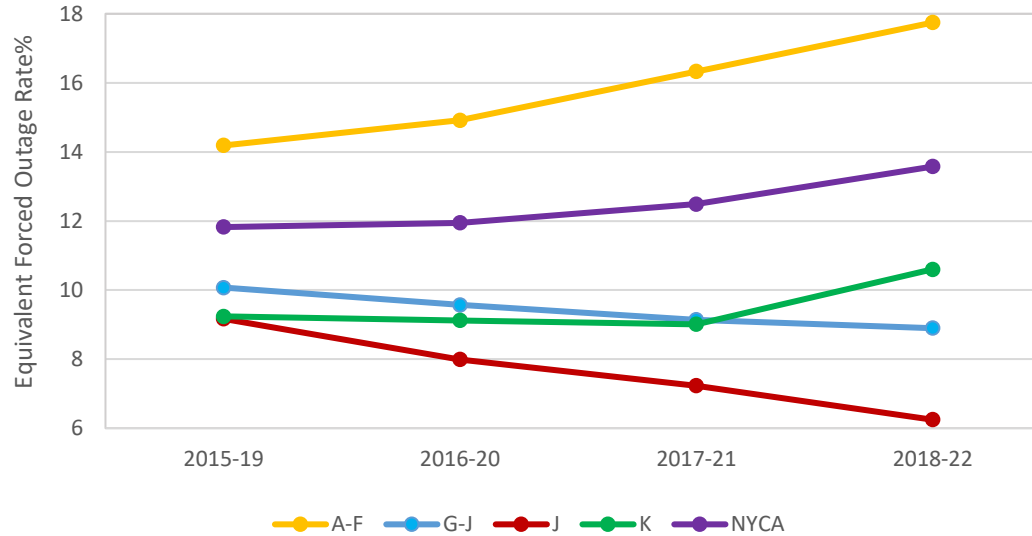

Attachment D

Emergency Operating Procedures

Step	Procedure	2023 IRM MW Value	2024 IRM MW Value
1	Special Case Resources –Load, Gen	1,224 MW Enrolled/ 860 MW Modeled	
2	5% manual voltage Reduction	85.43 MW	
3	Thirty-minute reserve to zero	655 MW	
4	5% remote voltage reduction	452.92 MW	
5	Voluntary industrial curtailment	240.05 MW	
6	General Public Appeals	80 MW	
7	Emergency Purchases	Varies	
8	Ten-minute reserves to zero	960 MW (350 MW maintained at load shedding)	910 MW (400 MW maintained at load shedding)
9	Customer disconnections	As needed	
10	Adjustment used if IRM is lower than technical study margin	As needed	

Attachment E1

IRM Topology

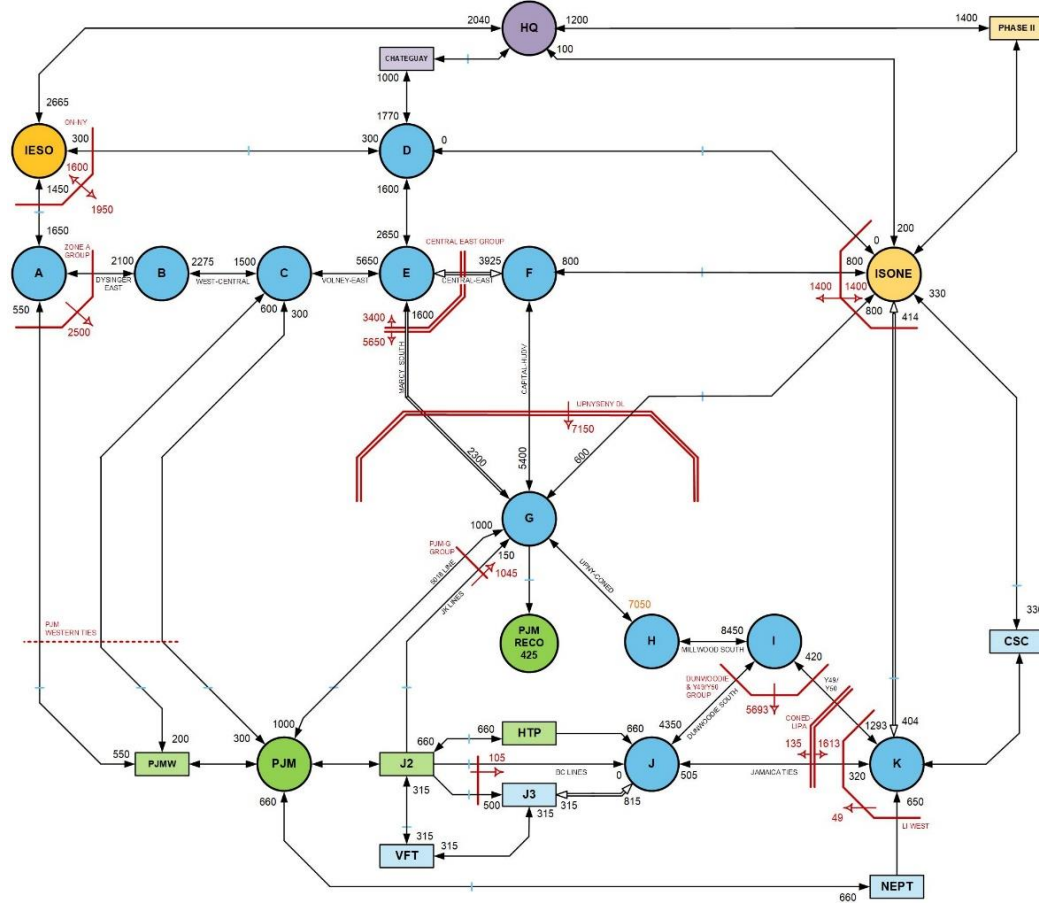

- Notes**
1. PJM to NY emergency assistance (EA) assumption for calculating the PJM-NY Western ties, PJM-G Group, and ABC Line Group flow distribution limit: 1500MW
 2. NYCA EA simultaneous import limit: 3,500 MW
 3. External areas representation based upon information received from the NPCC CP-8 WG

Legend

- ↔ Interface
- ↔ Unidirectional Interface
- ↔ Interface w/ Dynamic Ratings
- Interface Group
- Interface Group w/ Dynamic Ratings
- - - Monitoring Interface Group
- NYCA EA interface Group Marker
- xx "Dummy Bubble" i.e. no load

NOTE: An interface is considered to not have a MW limitation if no number is specified

Attachment E2

ISO-NE 14 Bubble Model

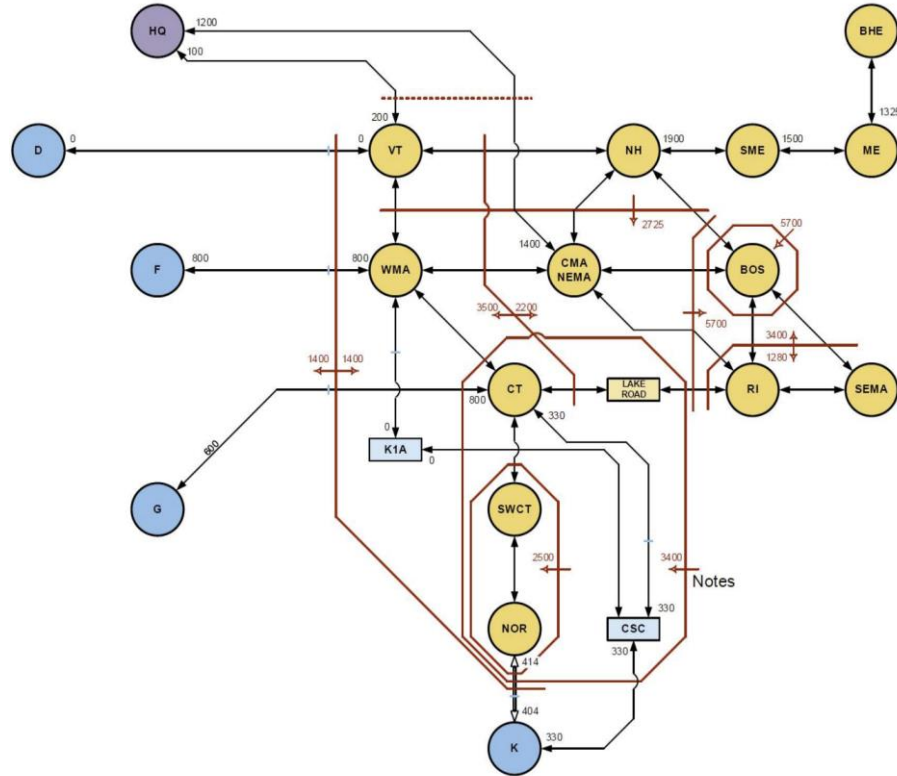

Attachment E3

PJM Bubble Model

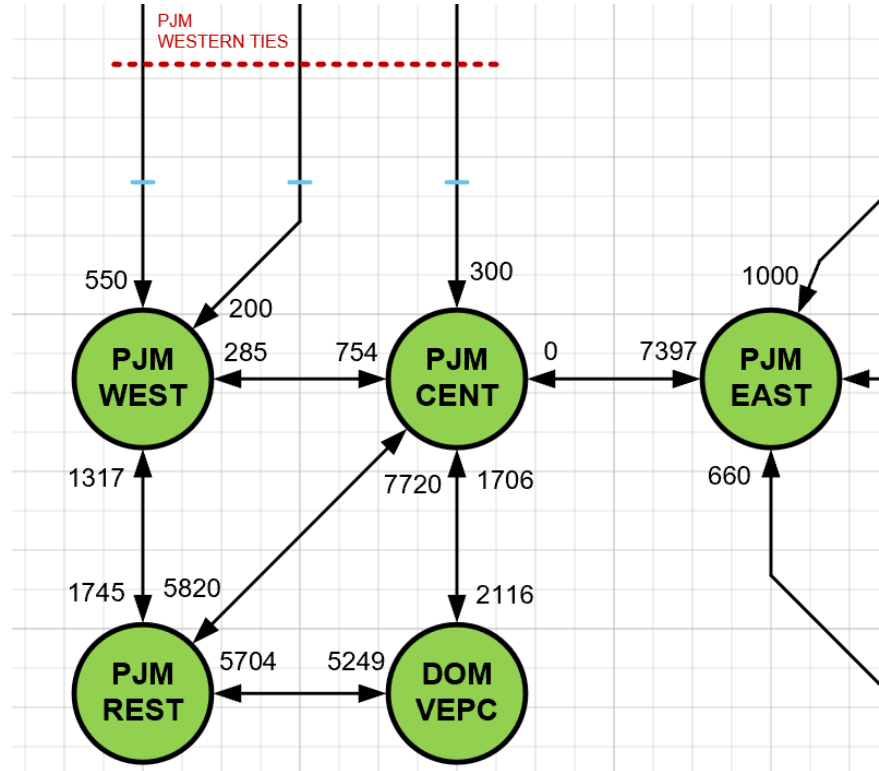

Attachment E4

5 Year Average Cable Outage Rate	
2017-21	2016-20
7.50%	6.42%

The facilities included in these averages are VFT, HTP, Dunwoodie-South, Y49/Y50, CSC, Neptune, Norwalk-Northport and A-Line.

Attachment F

To be updated for 2024-2025 IRM Study

SCR Determinations 2023 and 2024 IRM Studies

SCR Performance for 2023 IRM Study						
Super Zones	Enrollments (July 2021)	Forecast (2022) ⁶	Performance Factor ⁷	UCAP (2022)	Adjustment Factor ⁸	Model Value
A-F	694.5	694.5	0.867	602.3	0.949	571.8
G-I	79.1	79.1	0.773	61.2	0.843	51.6
J	417.5	417.5	0.705	294.4	0.744	219.1
K	33.7	33.7	0.696	23.4	0.763	17.9
Totals	1224.8	1224.8		981.4		860.4
					Overall Performance = 70.3%	

6. These values represent no growth from July 2020 ICAP based enrollments.

7. Performance Factor based on ACL methodology.

8. The SCR Adjustment factor captures two different performance derates; 1) Calculated Translation Factor (TF) between ACL and CBL values, and the Fatigue Factor (FF=1.00).

Attachment G

Wind Units Modeled

Resource	Wind			
	Zone	CRIS (MW)	Summer Capability (MW)	MARS Modeled Capability**
Bliss Wind Power [WT]	A	100.5	100.5	100.5
Canandaigua Wind Power [WT]	C	125.0	125.0	125.0
High Sheldon Wind Farm [WT]	C	112.5	118.1	112.5
Howard Wind [WT]	C	57.4	55.4	55.4
Orangeville Wind Farm [WT]	C	94.4	93.9	93.9
Wethersfield Wind Power [WT]	C	126.0	126.0	126.0
Altona Wind Power [WT]	D	97.5	97.5	97.5
Chateaugay Wind Power [WT]	D	106.5	106.5	106.5
Clinton Wind Power [WT]	D	100.5	100.5	100.5
Ellenburg Wind Power [WT]	D	81.0	81.0	81.0
Jericho Rise Wind Farm [WT]	D	77.7	77.7	77.7
Marble River Wind [WT]	D	215.2	215.2	215.2
Hardscrabble Wind [WT]	E	74.0	74.0	74.0
Madison Wind Power [WT]	E	11.5	11.6	11.5
Maple Ridge Wind [WT01]	E	231.0	231.0	231.0
Maple Ridge Wind [WT02]	E	90.7	90.8	90.7
Munnsville Wind Power [WT]	E	34.5	34.5	34.5
Arkwright Summit Wind Farm [WT]	A	78.4	78.4	78.4
Eight Point Wind Energy Center [WT]	C	101.2	111.2	101.2
Bluestone Wind [WT]	E	111.8	111.8	111.8
Number 3 Wind Energy [WT]	E	103.9	103.9	103.9
Ball Hill Wind [WT]	A	100.0	100.0	100.0
Baron Winds [WT]	C	300.0	121.8	121.8
South Fork Wind Farm (Off-Shore)	K	96.0	96.0	96.0
South Fork Wind Farm II (Off-Shore)	K	40.0	40.0	40.0
Total		2667.2	2502.3	2486.5

Attachment G1

Wind Units Not Currently Participating in ICAP Market

Wind					
Resource	Zone	Nameplate (MW)	CRIS (MW)	Summer Capability (MW)	MARS Modeled Capacity
Erie Wind [WT]	A	15.0	0.0	0.0	0.0
Steel Wind [WT]	A	20.0	0.0	0.0	0.0
Western NY Wind Power [WT]	B	6.6	0.0	0.0	0.0
Marsh Hill Wind Farm [WT]	C	16.2	0.0	0.0	0.0
Copenhagen Wind [WT]	E	79.9	79.9	0.0	0.0
Roaring Brook [WT]	E	79.7	79.7	0.0	0.0
Fenner Wind [WT]	C	30.0	30.0	0.0	0.0
Cassadaga Wind [WT]	A	126.0	126.0	0.0	0.0
Total		373.4	315.6	0.0	0.0

Attachment G2

Solar Units Modeled

Solar				
Resource	Zone	CRIS (MW)	Summer Capability (MW)	Lesser of Summer Capability vs. CRIS
Long Island Solar Farm [PV]	K	31.5	31.5	31.5
Calverton Solar Energy Center [PV]	K	22.9	22.9	22.9
Brandscomb Solar [PV]	F	20.0	20.0	20.0
Darby Solar [PV]	F	20.0	20.0	20.0
Grissom Solar [PV]	F	20.0	20.0	20.0
Janis Solar [PV]	C	20.0	20.0	20.0
Pattersonville Solar [PV]	F	20.0	20.0	20.0
Puckett Solar [PV]	C	20.0	20.0	20.0
ELP Stillwater Solar [PV]	F	20.0	20.0	20.0
Regan Solar [PV]	F	20.0	20.0	20.0
Albany County	F	20.0	20.0	20.0
Albany County II	F	20.0	20.0	20.0
East Point Solar	F	50.0	50.0	50.0
Total		304.4	304.4	304.4

Attachment G3

Solar Units Not Modeled

Solar				
Resource	Zone	CRIS (MW)	Summer Capability (MW)	Lesser of Summer Capability vs. CRIS
Shoreham Solar [PV]*	K	24.9	0.0	0.0
Total		24.9	0.0	0.0

*Unit provides power at the distribution rather than at the transmission level.

Attachment G4

LFG Units Modeled

LFG				
Resource	Zone	CRIS (MW)	Summer Capability (MW)	Lesser of Summer Capability VS CRIS
CHAFEE [IC]	A	6.4	6.4	6.4
Model City Energy LFGE [IC]	A	5.6	5.6	5.6
Modern LFGE [IC]	A	6.4	6.4	6.4
Hyland LFGE [IC]	B	4.8	4.8	4.8
Mill Seat [IC]	B	6.4	6.4	6.4
Broome 2 [IC]	C	2.0	2.1	2.0
Broome LFGE [IC]	C	2.1	2.4	2.1
High Acres Group [IC] (23767)	C	9.6	9.6	9.6
Ontario LFGE [IC]	C	11.2	11.2	11.2
Seneca Energy Group [IC] (23797)	C	17.6	17.6	17.6
Clinton LFGE [IC]	D	6.4	6.4	6.4
DANC LFGE [IC]	E	6.4	6.4	6.4
Oneida-Herkimer LFGE [IC]	E	3.2	3.2	3.2
Colonie LFGTE [IC]	F	6.4	6.4	6.4
Fulton County Landfill [IC]	F	3.2	3.2	3.2
Totals		97.7	98.1	97.7

Attachment G5

LFG Units Not Modeled

LFG				
Resource	Zone	CRIS (MW)	Summer Capability (MW)	Lesser of Summer Capability VS CRIS
Chautauqua LFGE	A	9.6	0.0	0.0
Synergy Biomass	B	2.0	0.0	0.0
Madison County LFGE [IC]	E	1.6	0.0	0.0
Total		13.2	0.0	0.0

Assumption Matrix History

Date	Ver	Preliminary Base Case	Date	Ver	Final Base Case
2/1/23	V0.0	Preliminary assumptions without attachments			
3/28/23	V1.0	Preliminary assumptions with Attachment C			
5/3/23	V2.0	Preliminary assumptions with Attachment A1, B3 Updates to Attachments D (item #8), G, and G1-G5			
5/30/23	V3.0	Preliminary assumptions with Attachment B2, D (item #8), and E1-E3			