

# IRM Topology Update

## - *Dover PAR Delay*

---

Yvonne Huang

NYISO

**ICS #281**

October 4, 2023

# Background

- **Segment B of the AC Tx was expected to be in service by the end of 2023. Therefore, the 2024-2025 IRM PBC reflected the assumption with improved transfer limits due to AC Tx project fully in service.**
  - These transfer limits are aligned with the 2022 RNA for Year 2024
- **In June 2023, Transco reported that the development work at Dover PAR was halted due to local permit being challenged by State Supreme Court and December 2023 i/s date is no longer feasible.**
- **The delay of the Dover PAR construction will impact several interface transfer limits as it affects the amount of series compensation can be assumed at Knickerbocker.**
  - ICS has previously requested a sensitivity case on this year's IRM PBC to reflect the delay of Dover PAR
- **At this point, the expectation for the i/s date for Segment B could be late 2024, making the delay of Dover PAR the base case assumptions for the 2024-2025 IRM.**

# Topology Impacts – Central East

- The delay of the Dover PAR is expected to affect the Central East voltage limit due to the bypassing of the PAR and series compensation at Knickerbocker
- NYISO Operations has updated the Central East Voltage Limits and showed a small reduction from the current IRM assumptions ([Updated Central East Voltage Limits](#))
- NYISO tested the updated Central East Voltage Limits on this year’s PBC and confirmed no IRM impact due to the change
  - Proportional adjustments are also applied to the limit of Central East + Marcy group

Forward Limits (MW)	Central East	Central East + Marcy Group
2024 – 2025 IRM PBC	3925/3875/3815/ 3710/3595/3470	5650/5575/5490/ 5335/5160/4960
Proposed Change for 2024 – 2025 IRM FBC	3885/3805/3725/ 3640/3540/3460	5590/5475/5360/ 5235/5080/4945
Delta	-40/-70/-90/ -70/-55/-10	-60/-100/-130/ -100/-80/-15

# Topology Impacts – UPNYSENY

- **Bypassing of the Dover PAR and series compensation at Knickerbocker will also impact the UPNYSENY transfer limit**
- **Detailed study about the reduction on the UPNYSENY transfer limit, as compared to AC Tx fully in service, has not been completed**
  - Based on NYISO internal preliminary studies, the reduction on UPNYSENY transfer limit is expected to be within a few hundreds MW
- **NYISO tested the scenario of reverting the UPNYSENY transfer limit back to last year’s FBC assumption, and confirmed no IRM impact**
  - Reverting the improvement on UPNYSENY transfer limit represents 1900 MW reduction on the PBC assumption
- **Given the lack of completed detailed study and the expectation of no impact on the IRM study, the NYISO propose to make no change to the UPNYSENY transfer limit in the 2024-2025 IRM FBC to account for the delay of Dover PAR**
  - A footnote should be added in the Assumptions Matrix to provide clarity and transparency

# Topology Updates – Additional Cleanup

- During the data QA review at the PBC, GE and TOs had identified a few errors on the Assumption Matrix in the topology section
  - Modeling in the database has been confirmed correct
- Therefore, the following transfer limits in the Assumption Matrix topology section will be updated

Transfer Limits	PBC Assumption Matrix	PBC Database	Proposed Change for FBC Assumption Matrix
I to J Forward Limits	4350	4400	4400
Neptune Reverse Limit	650	660	660

- No modeling change is required

# 2024 – 2025 IRM PBC Topology for New York Control Area

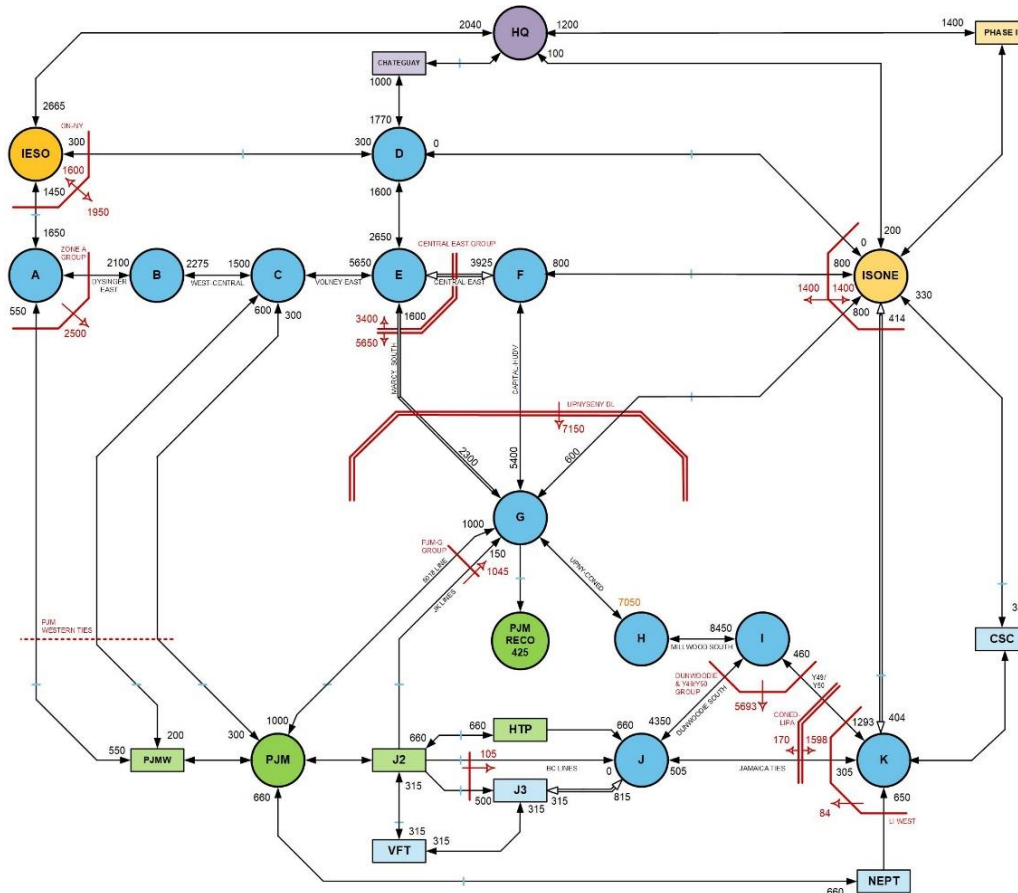

## Notes

1. PJM to NY emergency assistance (EA) assumption for calculating the PJM-NY Western ties, PJM-G Group, and ABC Line Group flow distribution limit: 1500MW
2. NYCA EA simultaneous import limit: 3,500 MW
3. External areas representation based upon information received from the NPCC CP-8 WG

## Legend

- ↔ Interface
  - Unidirectional Interface
  - ↔ Interface w/ Dynamic Ratings
  - Interface Group
  - Interface Group w/ Dynamic Ratings
  - Monitoring Interface Group
  - - - NYCA EA Interface Group Marker
  - xx "Dummy Bubble" i.e. no load
- NOTE: An interface is considered to not have a MW limitation if no number is specified

# Updated Transfer Limits for 2024-2025 IRM FBC

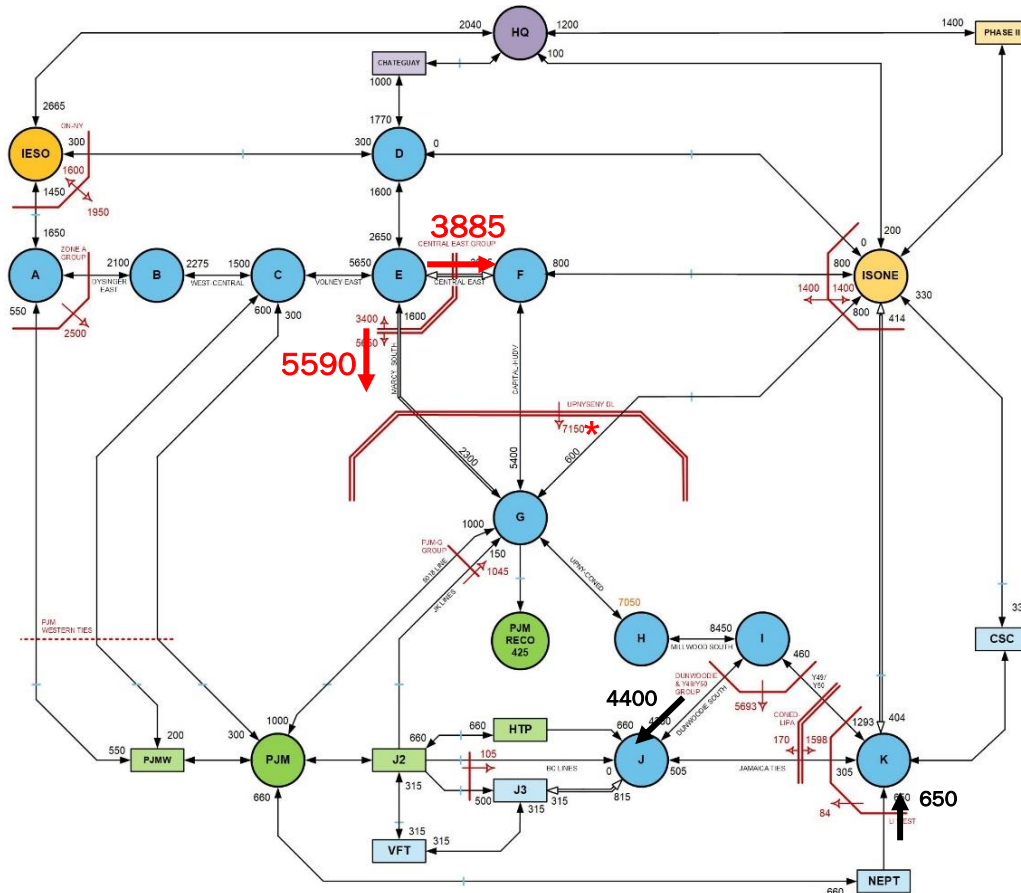

## Notes

1. PJM to NY emergency assistance (EA) assumption for calculating the PJM-NY Western ties, PJM-G Group, and ABC Line Group flow distribution limit: 1500MW
2. NYEA EA simultaneous import limit: 3,500 MW
3. External areas representation based upon information received from the NPCC CP-8 WG

## Legend

- Interface
  - Unidirectional Interface
  - Interface w/ Dynamic Ratings
  - Interface Group
  - Interface Group w/ Dynamic Ratings
  - Monitoring Interface Group
  - NYEA EA Interface Group Marker
  - xx "Dummy Bubble" i.e. no load
- NOTE: An interface is considered to not have a MW limitation if no number is specified

\* The UPNYSNY transfer limit is expected to be reduced due to the delay of the construction of DOVER PAR. However, the reduction is not expected to be impactful.

# Proposed 2024 – 2025 IRM FBC Topology for New York Control Area

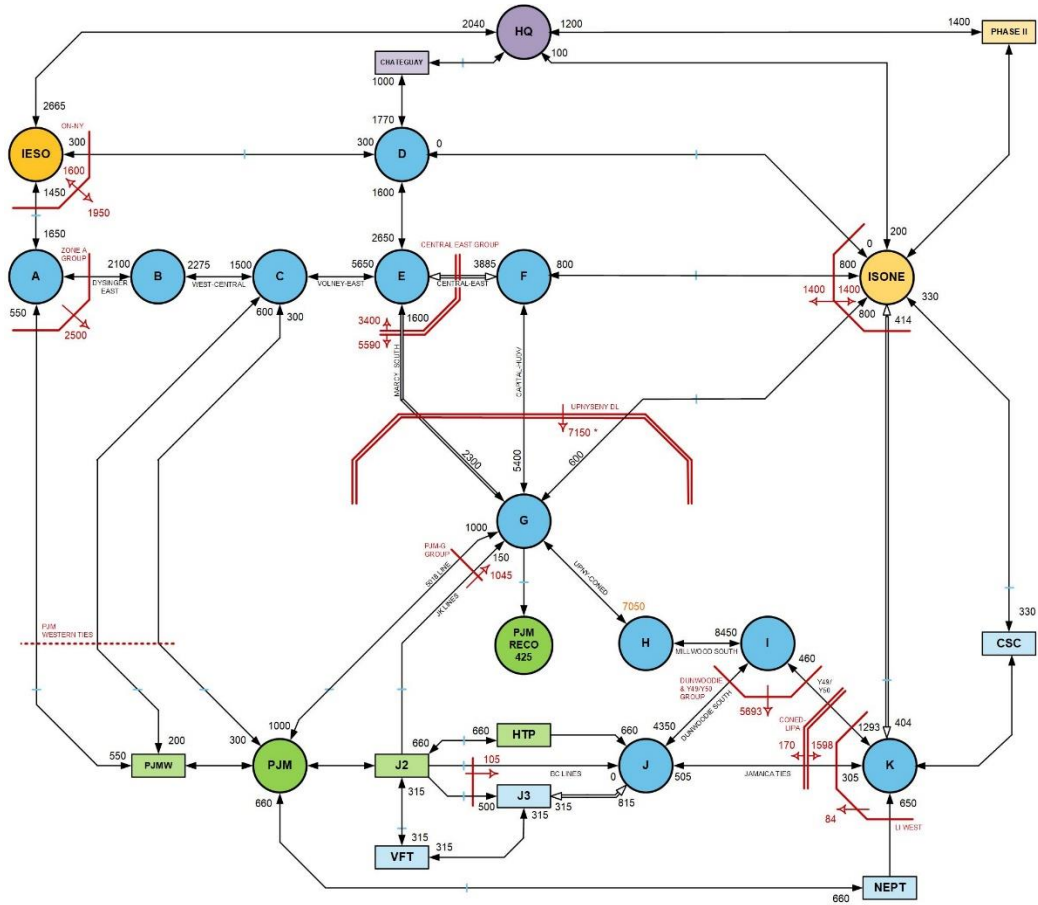

- Notes**
1. PJM to NY emergency assistance (EA) assumption for calculating the PJM-NY Western ties, PJM-G Group, and ABC Line Group flow distribution limit: 1500MW
  2. NYCA EA simultaneous import limit: 3,500 MW
  3. External areas representation based upon information received from the NPCC CP-8 WG

**Legend**

- ↔ Interface
- Unidirectional Interface
- ↔ Interface w/ Dynamic Ratings
- Interface Group
- Interface Group w/ Dynamic Ratings
- - - Monitoring Interface Group
- - - NYCA EA Interface Group Marker
- XX "Dummy Bubble" i.e. no load

NOTE: An interface is considered to not have a MW limitation if no number is specified

\* The UPNYSENY transfer limit is expected to be reduced due to the delay of the construction of DOVER PAR. However, the reduction is not expected to be impactful.





# Our Mission & Vision



## Mission

Ensure power system reliability and competitive markets for New York in a clean energy future



## Vision

Working together with stakeholders to build the cleanest, most reliable electric system in the nation

# Questions?