

2027-2028 IRM Preliminary Base Case: Proposed Topology Updates

Ava Sealander

ICS Meeting #317

June 3, 2026

Overview

- **Proposed internal New York Control Area (NYCA) topology updates for the 2027-2028 installed reserve margin (IRM) study preliminary base case (PBC)**
 - Dysinger East forward limit
 - West Central reverse seasonal limits
 - Moses South forward limit
- **Next steps**

Proposed Dysinger East Forward Limit

- **The 2026 NYISO Summer Operating Study reported a 25 MW decrease in emergency transfer limits on the Dysinger East forward interface**
 - The decrease is driven by changes in equipment ratings and flow patterns with changes in interface definition due to the addition of the Byron and Graham stations on the 345 kV system
 - The NYISO does not expect significant changes to the system conditions in 2027 summer compared to 2026 summer
- **The NYISO recommends decreasing the interface limit from Load Zone A to Load Zone B to 1,900 MW in the 2027-2028 IRM study**

| Dysinger East | Forward Limit (MW) |
|---------------------------------------|--------------------|
| 2026-2027 IRM Study | 1925 |
| Proposed Update for 2027-2028 IRM PBC | 1900 |
| Delta | (25) |

Proposed West Central Reverse Limit (Summer)

- **The 2026 NYISO Summer Operating Study updated the West Central reverse transfer limit to 2,125 MW from 2,225 MW in 2025 Summer**
 - The reduction is attributed to changes in post-contingency loading
 - The NYISO does not expect significant changes to the system conditions in 2027 summer compared to 2026 summer
- **The NYISO recommends decreasing the interface transfer limit from Load Zone C to Load Zone B during the summer months to 2,125 MW in the 2027-2028 IRM study**

| West Central | Summer Reverse Limit (MW) |
|--|----------------------------------|
| 2026-2027 IRM Study | 2,225 |
| Proposed Summer Update for 2027-2028 IRM PBC | 2,125 |
| Delta | (100) |

Proposed West Central Reverse Limit (Winter)

- During the development of the Seasonal Topology update procedure,^[1] the NYISO identified the West Central reverse limit as potentially impactful to winter risk. The NYISO proposed including winter interface limits for West Central reverse in the 2027-2028 IRM study at the 4/28/2026 ICS meeting
- The 2025-2026 NYISO Winter Operating Study established the winter emergency thermal transfer limits for the West Central reverse interface of 2,750 MW
 - At this time, the NYISO does not expect significant changes to the system conditions for 2027-2028 Winter
- The NYISO recommends implementing a winter transfer limit from Load Zone C to Load Zone B of 2,750 MW in the 2027-2028 IRM Preliminary Base Case
 - Following the seasonal topology update procedure, the 2026-2027 NYISO Winter Operating Study will be monitored for potential updates in the 2027-2028 IRM Final Base Case

| West Central | Winter Reverse Limit (MW) |
|--|---------------------------|
| 2026-2027 IRM Study (Annual) | 2,225 |
| 2025-2026 NYISO Winter Operating Study Limit | 2,750 |
| Proposed Winter Update for 2027-2028 IRM PBC | 2,750 |

[1] [Seasonal Topology Update](#)

Proposed Moses South Forward Limit

- In advance of the interconnection of the Smart Path Connect (SPC) project components, the NYISO anticipated an increase in emergency transfer limits related to the project and increased the Moses South forward limit modeled in the 2026-2027 IRM study to 3,500 MW from 2,650 MW ^[2] in alignment with assumptions used in the 2025 Q1 Short Term Assessment of Reliability (STAR)
- The 2026 NYISO Summer Operating Study identified an emergency thermal transfer limit of 3,250 MW with the addition of the SPC project. After publication of the interface limits, the NYISO subsequently identified a short-term violation that is anticipated to further reduce the emergency transfer limit to 3,000 MW
 - The NYISO anticipates this reduction in the emergency thermal transfer limits across the interface to persist into 2027
- The NYISO proposes to decrease the transfer limit from Load Zone D to Load Zone E in the 2027-2028 IRM study

| Moses South | Forward Limit (MW) |
|---------------------------------------|--------------------|
| 2026-2027 IRM Study | 3,500 |
| Proposed Update for 2027-2028 IRM PBC | 3,000 |
| Delta | (500) |

Next Steps

- The NYISO proposes to incorporate the previously described adjustments to the Dysinger East forward, West Central reverse seasonal, and Moses South forward interface limits for the 2027-2028 IRM PBC
- The NYISO will monitor any additional interface limit updates made public prior to the finalization of the PBC assumptions matrix.
 - If there are no additional transfer limit updates identified, the NYISO proposes to maintain the other existing topology limits used in the 2026-2027 IRM Final Base Case for the 2027-2028 IRM PBC

Questions?

Appendix

2026-2027 IRM Study Topology For NYCA

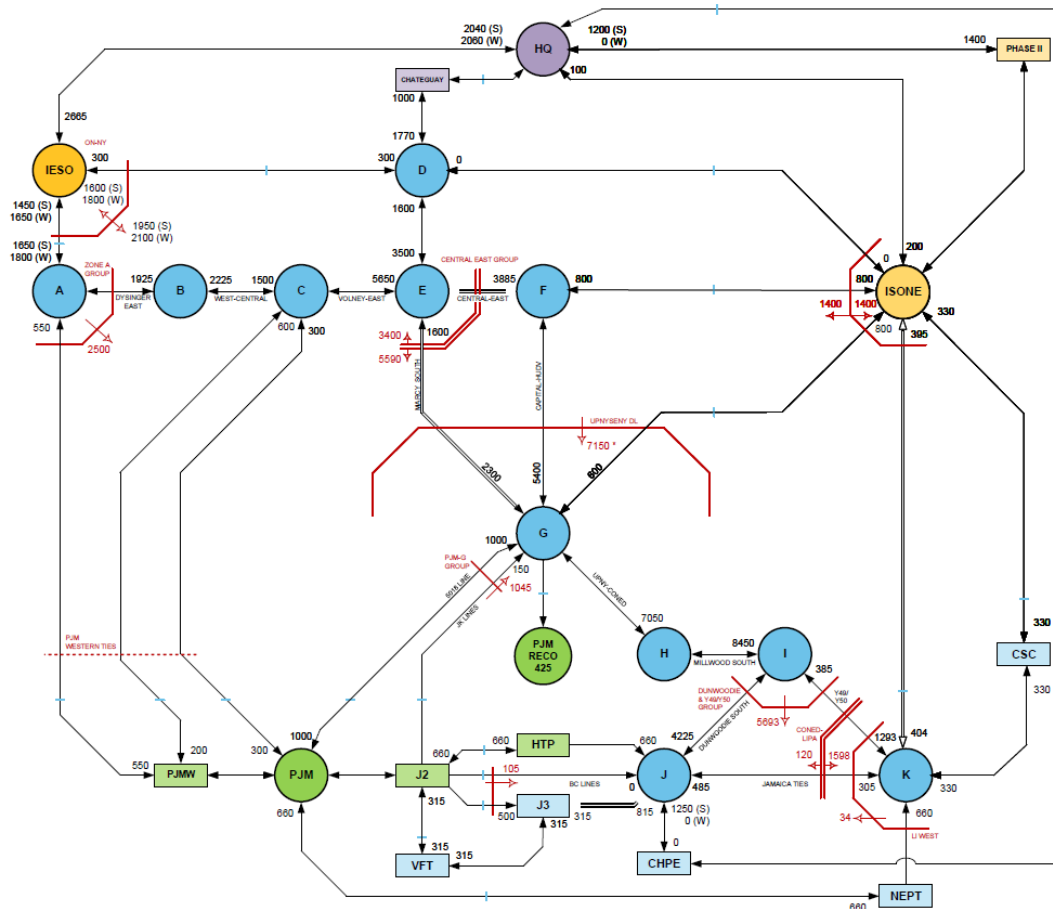

Notes

1. PJM to NY emergency assistance (EA) assumption for calculating the PJM-NY Western ties, PJM-G Group, and ABC Line Group flow distribution limit: 1500MW
2. NYCA EA simultaneous import limit: 3,500 MW
3. External areas representation based upon information received from the NPCC CP-3 WG

Legend

- Interface
 - Unidirectional Interface
 - Interface w/ Dynamic Ratings
 - Interface Group
 - Interface Group w/ Dynamic Ratings
 - Monitoring Interface Group
 - NYCA EA Interface Group Marker
 - xx "Dummy Bubble" i.e. no load
- NOTE: An interface is considered to not have a MW limitation if no number is specified

Proposed 2027-2028 IRM PBC Topology For NYCA

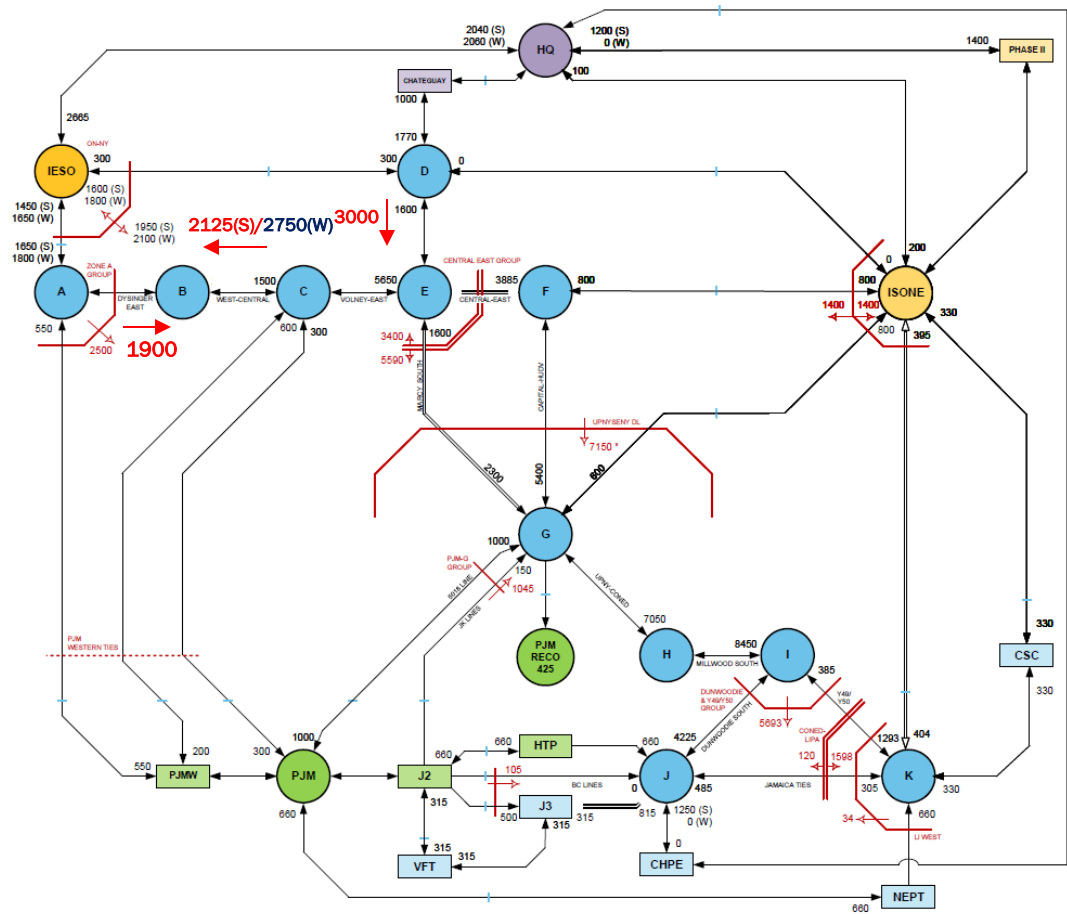

- Notes**
1. PJM to NY emergency assistance (EA) assumption for calculating the PJM-NY Western ties, PJM-G Group, and ABC Line Group flow distribution limit: 1500MW
 2. NYCA EA simultaneous import limit: 3,500 MW
 3. External areas representation based upon information received from the NPCC CP-8 WG

Legend

- ↔ Interface
- Unidirectional Interface
- ↔ Interface w/ Dynamic Ratings
- Interface Group
- Interface Group w/ Dynamic Ratings
- Monitoring Interface Group
- NYCA EA Interface Group Marker
- XX "Dummy Bubble" i.e. no load

NOTE: An interface is considered to not have a MW limitation if no number is specified

